

PA-550 LIBRO FOLDING do-it-yourself

SCORREVOLI A LIBRO / SLIDING FOLDING SYSTEMS / FALT-SCHIEBEWANDSYSTEME

MY METALGLAS

€ C.175



- Sistema scorrevole a libro con profili fermavetro continui a misura standard (mm 1000) da tagliare secondo necessità a cura del cliente, completi di catenaccioli fermaanta a posizionamento esterno regolabile. Vantaggi di una consegna più veloce e di un unico prodotto a magazzino per tutte le misure fino a 1000 mm.
- Sliding folding door system with continuous glass fixing profiles of a standard size (mm 1000) to be cut on the basis of client's requirements comes equipped with an adjustable door holding latch positioned externally. The advantage of this product is quick delivery and a unique product available in the warehouse for all sizes up to 1000 mm.
- Schiebesystem mit durchgehenden Glasteilenprofilen in Standardgröße (1000 mm), ablängbar, komplett mit äußeren einstellbaren Riegeln zur Flügelfeststellung. Vorteile einer raschen Lieferung und eines einzigen lagermäßigen Produktes mit Abmessungen bis 1000 mm.

SCORREVOLI A LIBRO
SLIDING FOLDING SYSTEMS

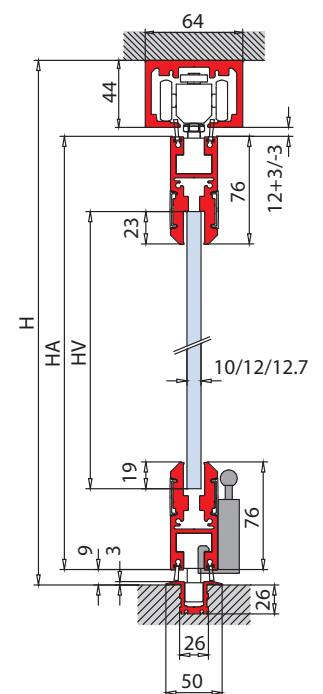

$HV = H - 176$



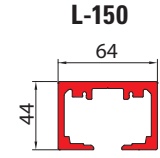
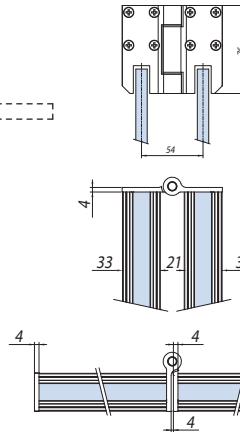
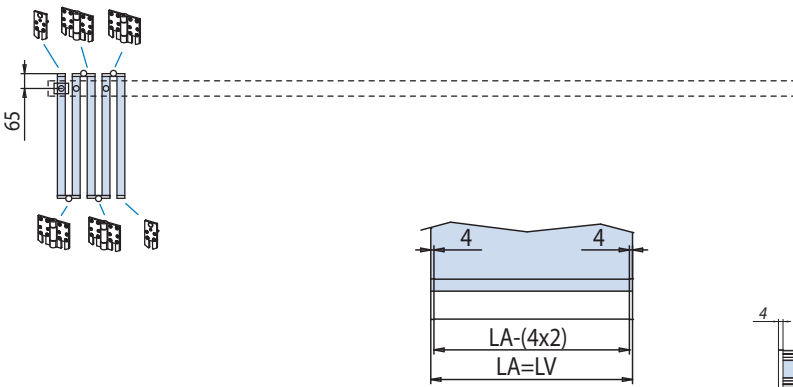
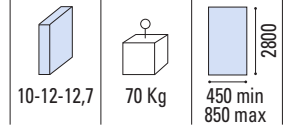
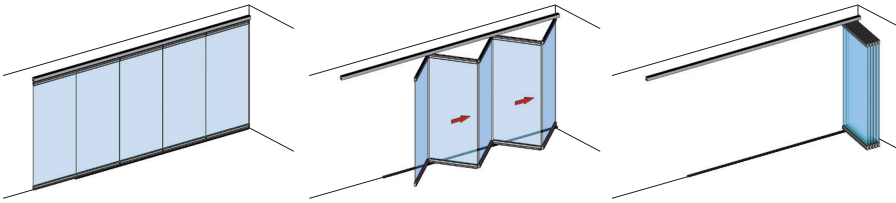

L-113 standard

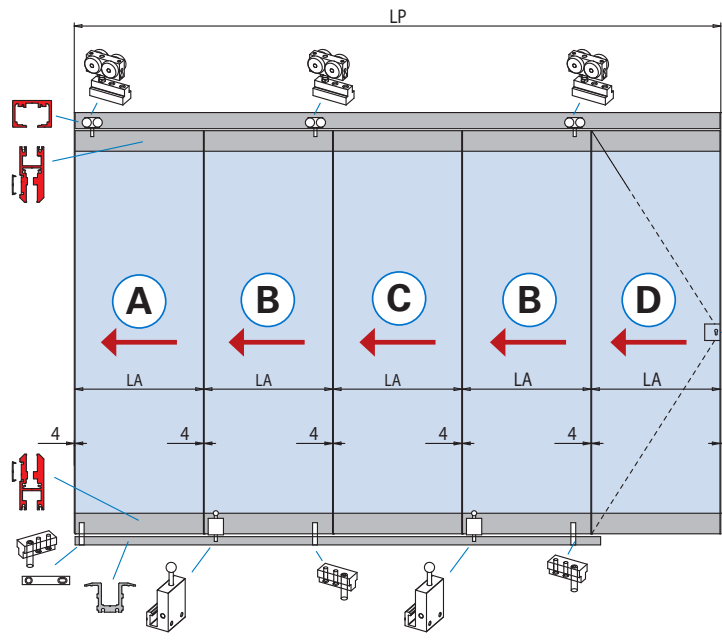
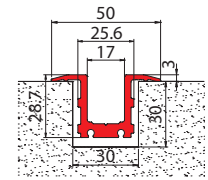

- Calcolo vetro
 - Calculation glass
 - Glasberechnung
- At = 4 x (N + 1)
 X = LP - At
 X = N x LA
 LA = LV = X / N

	PA-550 SET 2 (A E)
	PA-550 SET 3 (A B D)
	PA-550 SET 4 (A B C E)
	PA-550 SET 5 (A B C B D)
	PA-550 SET 6 (A B C B C E)
	PA-550 SET 7 (A B C B C B D)

- A**
- Prima anta a libro
 - First folding panel
 - Erster Faltelement
- B C**
- Anta intermedia a libro
 - Middle folding panel
 - Mittiges Faltelement
- D**
- Ultima anta porta battente con numero ante dispari
 - Last hinged door with odd no. panels
 - Letzter Dreh-Flügel bei ungerader Flügelanzahl
- E**
- Ultima anta con N° ante pari
 - Last panel with even no. panels
 - Letzter Flügel bei gerader Flügelanzahl

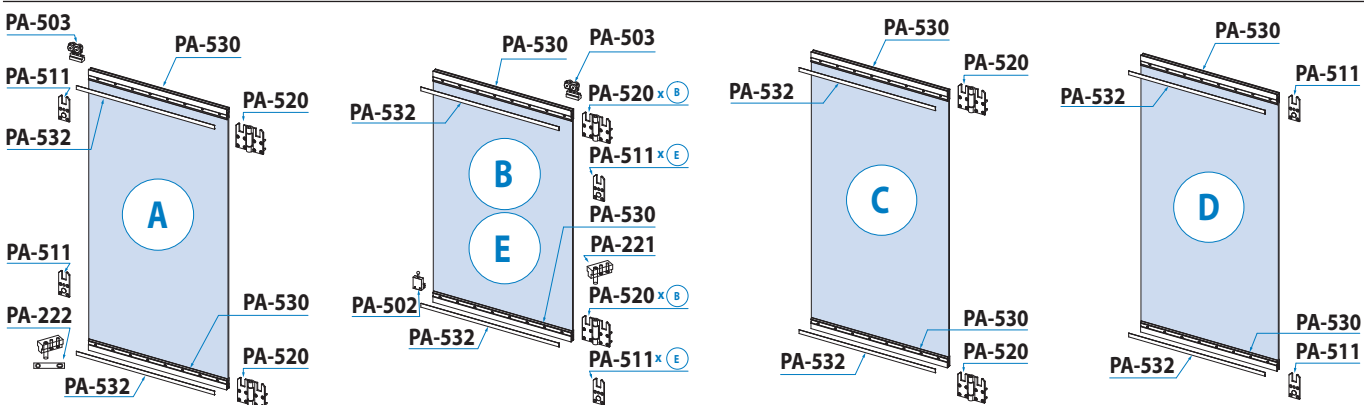

- B**
- Anta intermedia con catenaccio
 - Middle panel with latch
 - Zwischenflügel mit Riegel

- E**
- Ultima anta con N° ante pari
 - Last panel with even no. panels
 - Letzter Flügel bei gerader Flügelanzahl

- D**
- Ultima anta a porta battente con n° ante dispari
 - Last hinged door with odd no. panels
 - Letzter Drehflügel bei ungerader Flügelanzahl

xla342c-new / xla342c / xla342e / xla342-0

AN Alluminio anodizzato Aluminium anodized Aluminium Silberfarbig	At Arie totali Total clearances Summe alle Abstände Glas/Wand	N Numero ante Numbers panels Anzahl der Elemente	LP Passaggio luce Clear opening width Lichte Durchgangsbreite	LA = LV Larghezza ante = Larghezza vetro Panel width = Glass width Flügelbreite = Glasbreite	H Altezza passaggio luce Clear opening height Lichte durchgangshöhe	HV Altezza vetro Glass height Glashöhe	HA Altezza anta Door height Tür Höhe
---	---	--	---	--	---	--	--

SCORREVOLI A LIBRO SLIDING FOLDING SYSTEMS

PA-550 LIBRO FOLDING do-it-yourself

COME USARE MY METALGLAS / HOW TO USE MY METALGLAS / WIE MAN BENUTZT MY METALGLAS

1 INSERIRE LE MISURE DEL TUO VANO E LE ANTE DESIDERATE
ENTER THE MEASUREMENTS OF YOUR OPENING AND THE DOORS YOU REQUIRE
GEBEN SIE DIE MASSE IHRER ÖFFNUNG EIN UND DIE ERFORDERLICHEN TÜREN

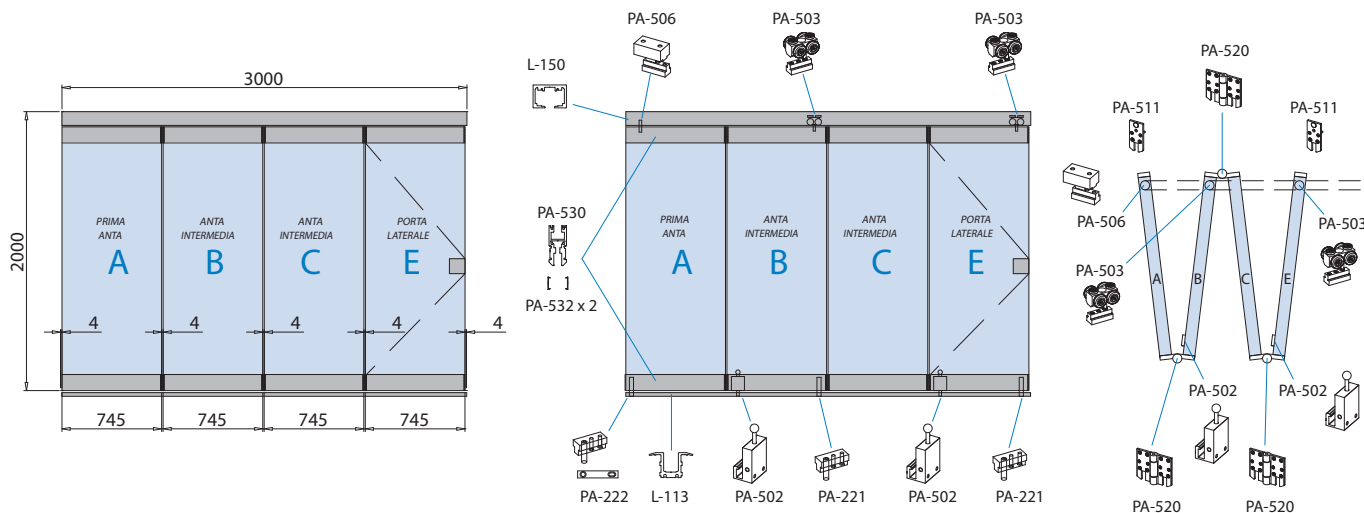

2 SI OTTENGONO LE MISURE DEI VETRI AUTOMATICAMENTE
THE MEASUREMENTS OF THE GLASS WILL BE GENERATED AUTOMATICALLY
DIE ABMESSUNGEN DES GLASES WERDEN AUTOMATISCH BERECHNET

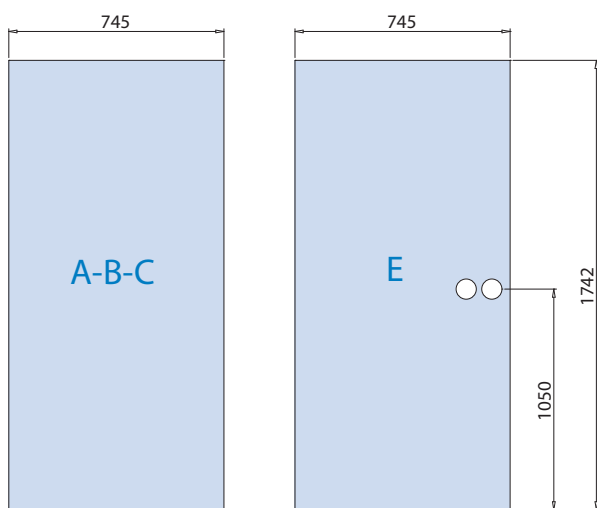

- Foratura vetro porta battente per serrature orizzontali optional
- Glass preparation pivot door for optional horizontal locks
- Glasbearbeitung Dreh-Flügel für optionale horizontale Schlösser

- Foratura vetro porta battente per serrature optional V-504, V-505, V-518, V-519, V-520
- Glass preparation pivot door for optional locks V-504, V-505, V-518, V-519, V-520
- Glasbearbeitung Dreh-Flügel für optionale Schlösser V-504, V-505, V-518, V-519, V-520

3 SI OTTENGONO LE DISTINTE DI TAGLIO DEI PROFILI, DA ABBINARE AGLI ACCESSORI
THE CUTTING SPECIFICATIONS OF THE PROFILES ARE OBTAINED, FOR MATCHING WITH THE ACCESSORIES
SIE ERHALTEN EINE SPEZIFIKATION DER PROFILLÄNGEN ZUM ABGLEICHEN MIT DEM ZUBEHÖR

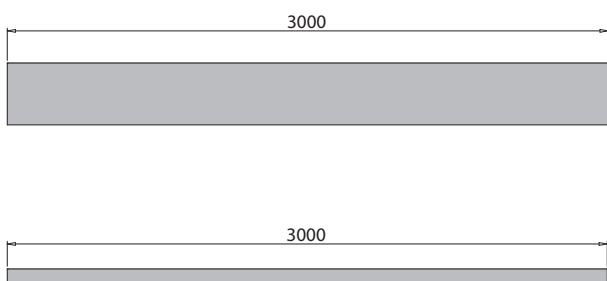

L-150



L-113



	PA-550 SET 2 (A)(E)
	PA-550 SET 3 (A)(B)(D)
	PA-550 SET 4 (A)(B)(C)(E)
	PA-550 SET 5 (A)(B)(C)(B)(D)
	PA-550 SET 6 (A)(B)(C)(B)(C)(E)
	PA-550 SET 7 (A)(B)(C)(B)(C)(B)(D)

PA-550 LIBRO FOLDING do-it-yourself

COME ASSEMBLARE LE ANTE / HOW TO ASSEMBLE THE DOORS / WIE DIE TÜREN ZUSAMMENSETZT WERDEN

TAGLIO PROFILI / PROFIL PREPARATION / PROFILBEARBEITUNG



KIT ACCESSORI / ACCESSORY SETS / ZUBEHÖR SETS



ANTA COMPLETA / COMPLETE DOOR / KOMPLETTE TÜR

ANTA A / DOOR A / TÜRA

PA-530
PA-532 (x 2)

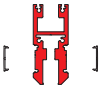

SUPERIORE / TOP / OBEN

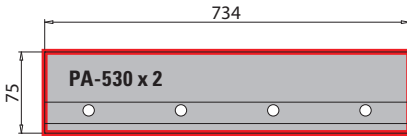

INFERIORE / BOTTOM / UNTEN

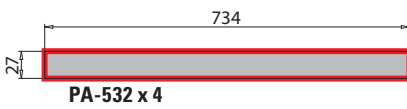

PA-550 ANTA A-10 (for glass 10 mm)
PA-550 ANTA A-12 (for glass 12 - 12,7 mm)
PRIMA ANTA A LIBRO A
FIRST FOLDING PANEL A
RSTER FALTELEMENT A

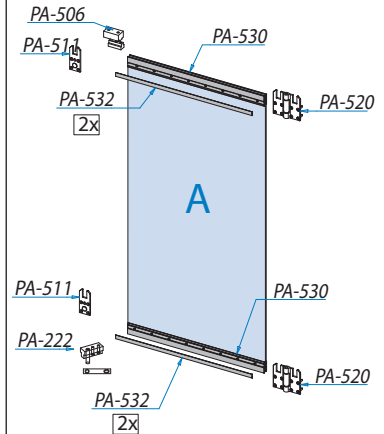

ANTA B / DOOR B / TÜRB

PA-530
PA-532 (x 2)

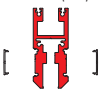

SUPERIORE / TOP / OBEN

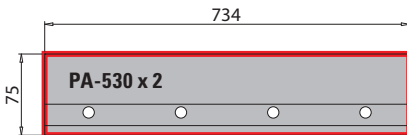

INFERIORE / BOTTOM / UNTEN

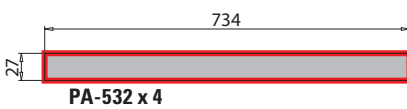

PA-550 ANTA B-10 (for glass 10 mm)
PA-550 ANTA B-12 (for glass 12 - 12,7 mm)
ANTA INTERMEDIA A LIBRO B
MIDDLE FOLDING PANEL B
MITTIGES FALTELEMENT B

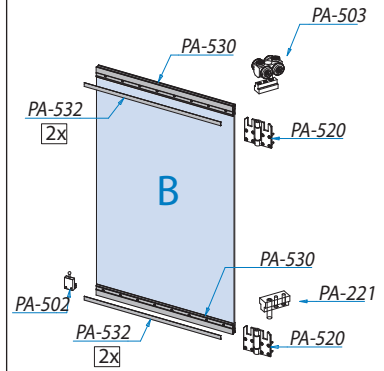
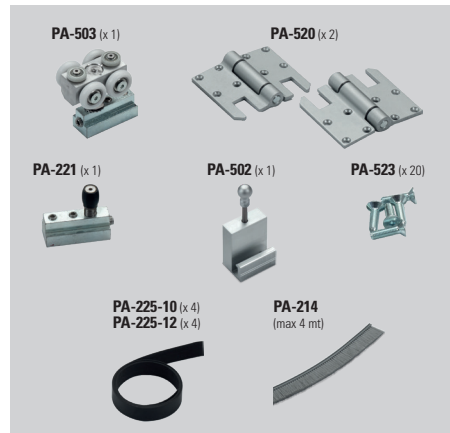

ANTA C / DOOR C / TÜRC

PA-530
PA-532 (x 2)

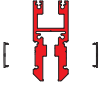

SUPERIORE / TOP / OBEN

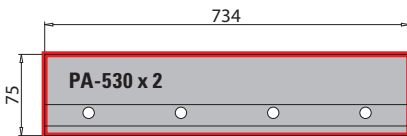

INFERIORE / BOTTOM / UNTEN

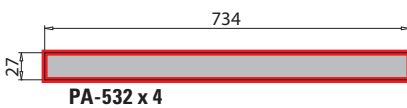

PA-550 ANTA C-10 (for glass 10 mm)
PA-550 ANTA C-12 (for glass 12 - 12,7 mm)
ANTA INTERMEDIA A LIBRO 2 C
MIDDLE FOLDING PANEL 2 C
MITTIGES FALTELEMENT 2 C

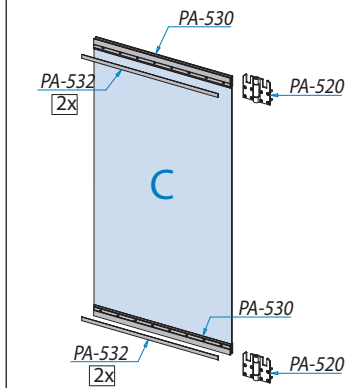
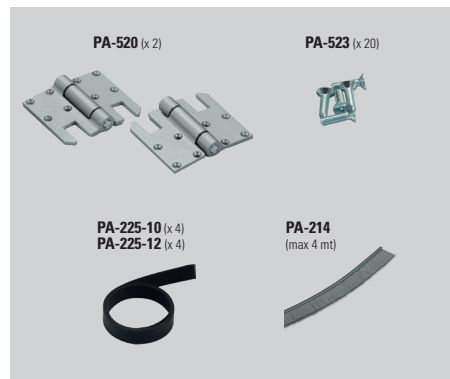

SCORREVOLI A LIBRO
SLIDING FOLDING SYSTEMS

PA-550 LIBRO FOLDING do-it-yourself

COME ASSEMBLARE LE ANTE / HOW TO ASSEMBLE THE DOORS / WIE DIE TÜREN ZUSAMMENSETZT WERDEN

TAGLIO PROFILI
PROFILES PREPARATION / PROFILEBEARBEITUNG



KIT ACCESSORI
ACCESSORY SETS / ZUBEHÖR SETS



ANTA COMPLETA
COMPLETE DOOR / KOMPLETTE TÜR

ANTA D / DOOR D / TÜR D

PA-530
PA-532 (x 2)

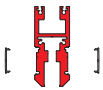

SUPERIORE / TOP / OBEN

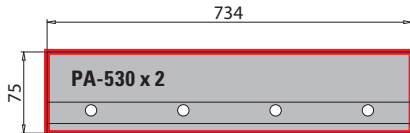

INFERIORE / BOTTOM / UNTEN

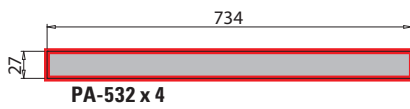

PA-550 ANTA D-10 (for glass 10 mm)
PA-550 ANTA D-12 (for glass 12 - 12,7 mm)
ULTIMA ANTA D (ante dispari)
LAST PANEL D (odd panels)
ENDSCHIEBEFLÜGEL D (ungerade Zahl von Flügel)

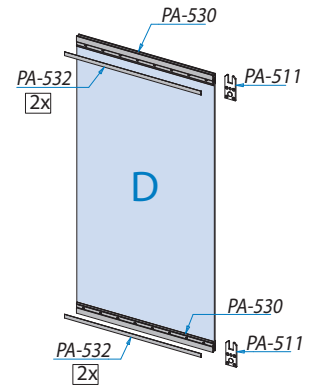
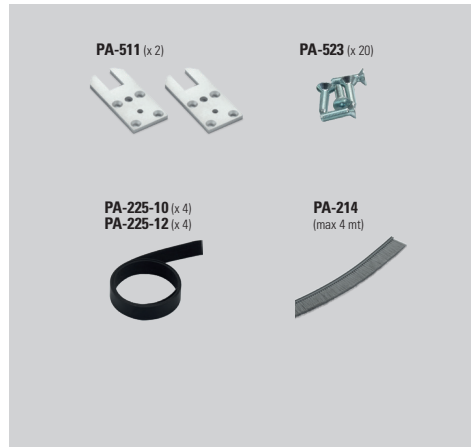

ANTA E / DOORE / TÜRE

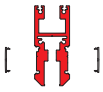

SUPERIORE / TOP / OBEN

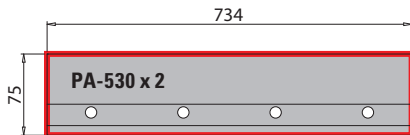

INFERIORE / BOTTOM / UNTEN

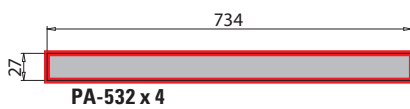

PA-550 ANTA E-10 (for glass 10 mm)
PA-550 ANTA E-12 (for glass 12 - 12,7 mm)
PORTA LATERALE E (ante pari)
LATERAL PIVOT DOOR E (even panels)
DREHSCHIEBEFLÜGEL E (gerade Zahl von Flügel)

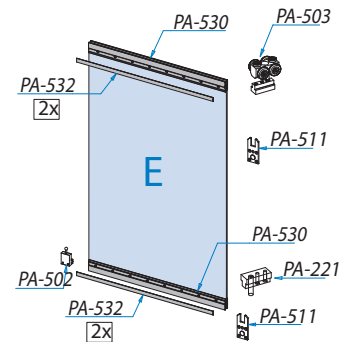
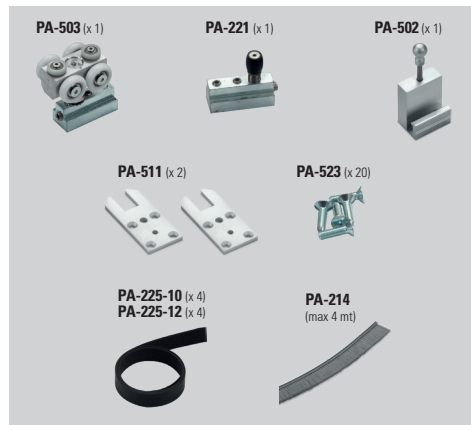

ANTA F / DOOR F / TÜR F

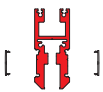

SUPERIORE / TOP / OBEN

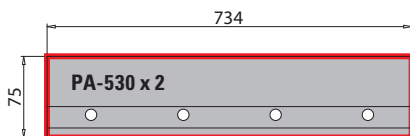

INFERIORE / BOTTOM / UNTEN



PA-550 ANTA F-10 (for glass 10 mm)
PA-550 ANTA F-12 (for glass 12 - 12,7 mm)
PORTA LATERALE FISSA F
FIXED LATERAL PIVOT DOOR F
FEST DREHSCHIEBEFLÜGEL F

