

PA-450 LIBRO FOLDING do-it-yourself

€ C.160

SCORREVOLI A LIBRO / SLIDING FOLDING SYSTEMS / FALT-SCHIEBEWANDSYSTEME



- Sistema scorrevole modulare a libro con morsetti fermavetro (mm 250) e veletta continua (mm 1200) da tagliare secondo necessità a cura del cliente.
- Sliding folding door system with glass fixing clamps (mm 250) and continuous covers (mm 1200) to be cut on the basis of client's requirements.
- Modulares Schiebesystem mit Gshalteklammen (250 mm) und kontinuierlicher Verkleidung (1200 mm), kundenspezifisch ablängbar.

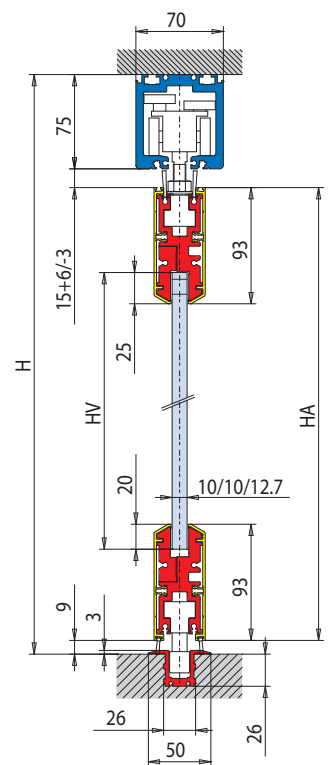

LAVORAZIONE VETRO x 2
GLASS PREPARATION x 2
GLASBEARBEITUNG x 2

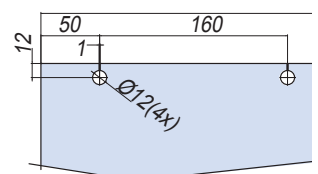

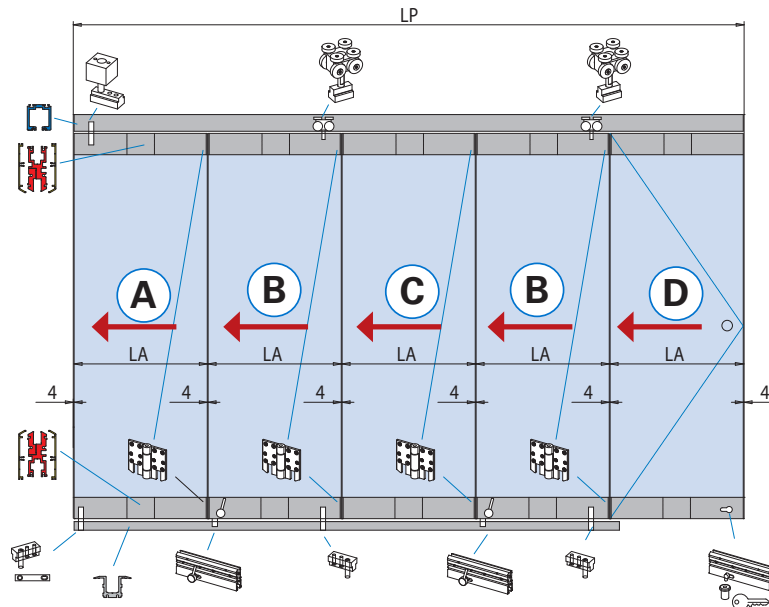
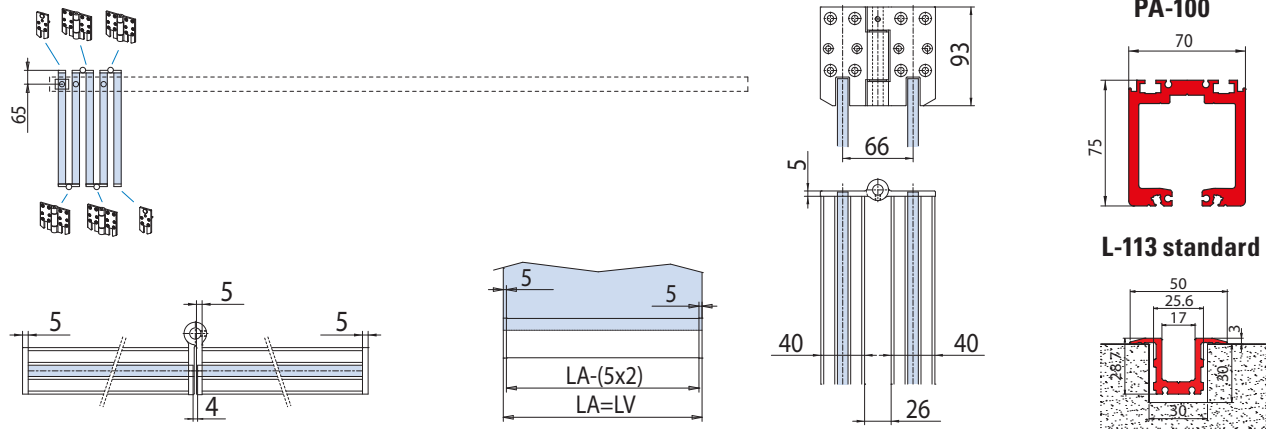
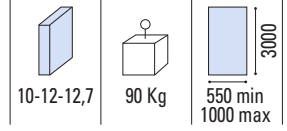
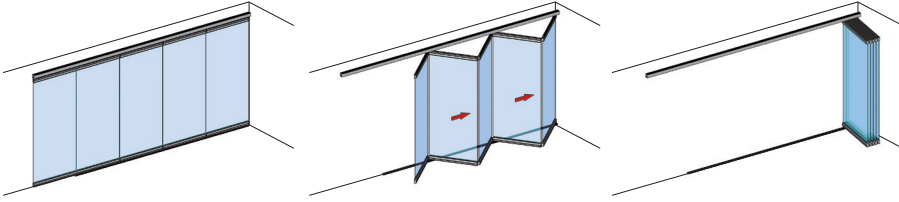

Calcolo vetro
Calculation glass
Glasberechnung

$$At = 4 \times (N + 1)$$

$$X = LP - At$$

$$X = N \times LA$$

$$LA = LV = X / N$$

- (A)**
 - Prima anta a libro
 - First folding panel
 - Erster Faltelement

- (B) (C)**
 - Anta intermedia a libro
 - Middle folding panel
 - Mittiges Faltelement

- (D)**
 - Ultima anta porta battente con numero ante dispari
 - Last hinged door with odd no. panels
 - Letzter Dreh-Flügel bei ungerader Flügelanzahl

- (E)**
 - Ultima anta con N° ante pari
 - Last panel with even no. panels
 - Letzter Flügel bei gerader Flügelanzahl

	PA-450 SET 2 (A E)
	PA-450 SET 3 (A B D)
	PA-450 SET 4 (A B C E)
	PA-450 SET 5 (A B C B D)
	PA-450 SET 6 (A B C B C E)
	PA-450 SET 7 (A B C B C B D)

SCORREVOLI A LIBRO
SLIDING FOLDING SYSTEMS

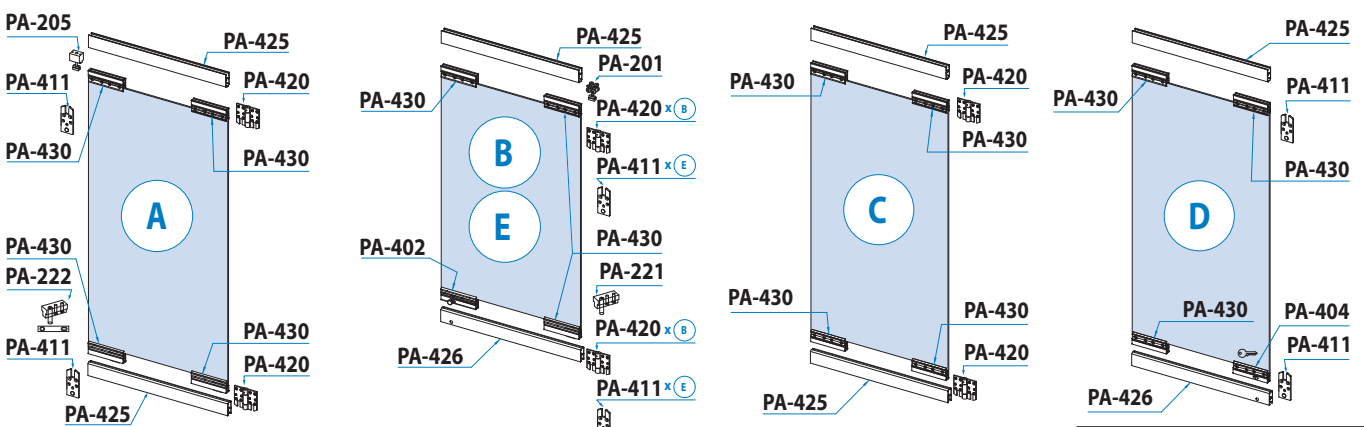

- (B)**
 - Anta intermedia con catenacciolo
 - Middle panel with latch
 - ZwischenFlügel mit Riegel
- (E)**
 - Ultima anta con N° ante pari
 - Last panel with even no. panels
 - Letzter Flügel bei gerader Flügelanzahl

- (D)**
 - Ultima anta a porta battente con n° ante dispari
 - Last hinged door with odd no. panels
 - Letzter DrehFlügel bei ungerader Flügelanzahl

xla334-0 / xla334g / xla334c

AN Alluminio anodizzato Aluminium anodized Aluminium Silberfarbig	At Arie totali Total clearances Summe alle Abstände Glas/Wand	N Numero ante Numbers panels Anzahl der Elemente	LP Passaggio luce Clear opening width Lichte Durchgangsbreite	LA = LV Larghezza ante = Larghezza vetro Panel width = Glass width Flügelbreite = Glasbreite	H Altezza passaggio luce Clear opening height Lichte durchgangshöhe	HV Altezza vetro Glass height Glashöhe	HA Altezza anta Door height Tür Höhe
---	---	--	---	--	---	--	--