

PA-300 PARK LINE 2

SCORREVOLI A PARCHEGGIO / SLIDING STACKING SYSTEMS / GANZGLAS-SCHIEBEWANDSYSTEME

- Sistema scorrevole a parcheggio con profili fermavetro su misura richiesta dal cliente, senza fori nel vetro e con possibilità di porta centrale a battente e parcheggiabile.
- Sliding stacking system with glass fixing profiles made to measure upon client's request, no need to make holes in the glass and with the possibility of hinged and parkable central panel.
- Schiebesystem mit Parkraum, mit kundenspezifischen Glasleistenprofile mit zentraler Drehtür und Parkmöglichkeit.

MY METALGLAS

€ ▶ C.17

€ ▶ C.18

SCORREVOLI A PARCHEGGIO
SLIDING STACKING SYSTEMS

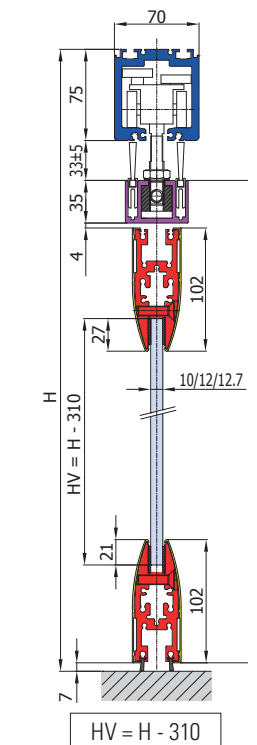
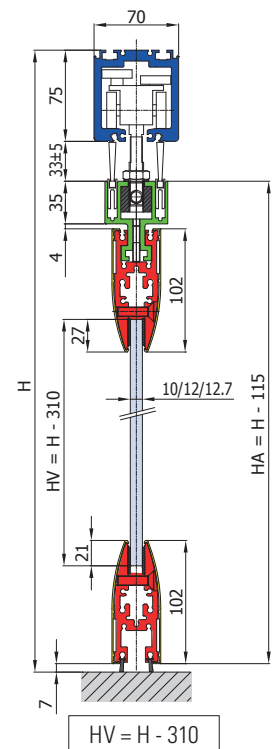
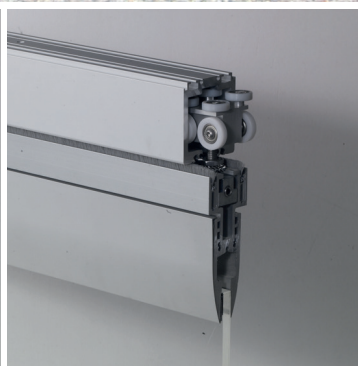

- Porta centrale scorrevole
- Central sliding pivoted door
- Dreh/pendel Schiebefügel

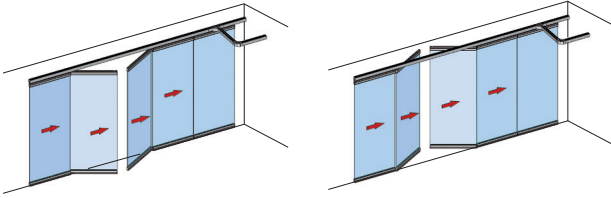

10-12-12,7	150 Kg	110 Kg	3500 550 min 1250 max
------------	--------	--------	-----------------------------

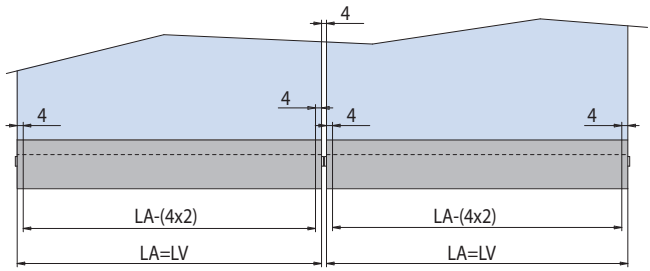
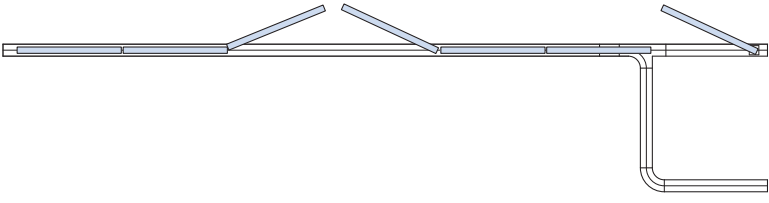

PA-108

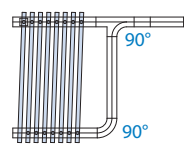

PA-109

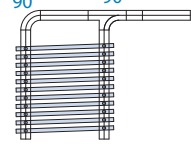

PA-113

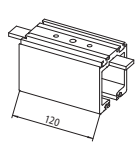

L-112-PA

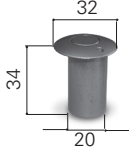

- Baie da ordinare a parte oltre alle ante, altre baie disponibili da pag. 60
- To be ordered separately from the panels, other parking bays available from page 60
- Neben den Flügel extra zu bestellen, andere Parkräume auf Seite 60

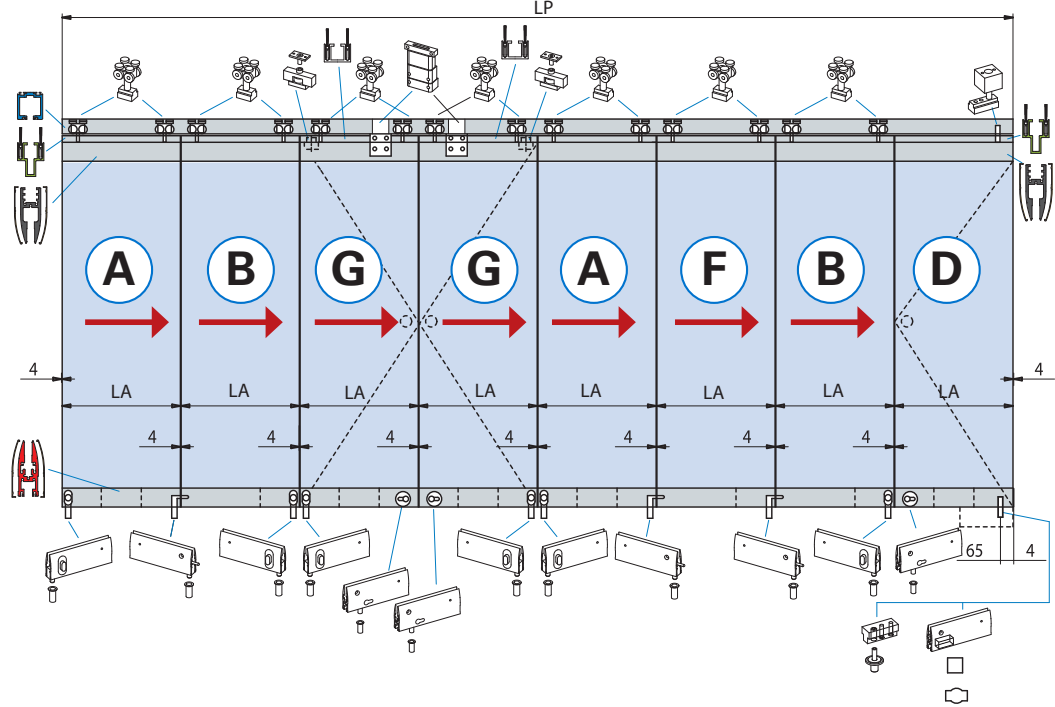

- Calcolo vetro
 - Calculation glass
 - Glasberechnung
- At = 4 x (N + 1)
X = LP - At
X = N x LA
LA = LV = X / N

- (A)**
 - Prima anta
 - First panel
 - Erster Schiebeflügel
- (B)**
 - Ultima anta
 - Last panel
 - End-Schiebeflügel
- (G)**
 - Porta centrale scorrevole dx/sx
 - Central sliding pivoted dx/sx
 - Dreh/pendel Schiebeflügel dx/sx
- (F)**
 - Anta intermedia
 - Intermediate panel
 - Zwischen-Schiebeflügel
- (D)**
 - Porta laterale
 - Lateral pivot door
 - Dreh-Schiebeflügel

xme295 / xla171BIS-1

AN Alluminio anodizzato Aluminium anodized Aluminium Silberfarbig	At Arie totali Total clearances Summe alle Abstände Glas/Wand	N Numero ante Numbers panels Anzahl der Elemente	LP Passaggio luce Clear opening width Lichte Durchgangsbreite	LA = LV Larghezza ante = Larghezza vetro Panel width = Glass width Flügelbreite = Glasbreite	H Altezza passaggio luce Clear opening height Lichte durchgangshöhe	HV Altezza vetro Glass height Glashöhe	HA Altezza anta Door height Tür Höhe
---	---	--	---	--	---	--	--

PA-632

- Scambio per convertire l'anta porta battente del PA-300 in anta scorrevole parcheggiabile tramite l'apposita chiave snodata
- Mechanism to convert the central pivoted door of PA-300 in sliding door parkable through the appropriate tool
- System um die zentrale Dreh-Tür des PA-300 in Schiebetür durch das entsprechende Werkzeug umzuwandeln

PA-300 CHIAVE



PA-308

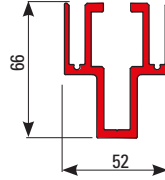

PA-309

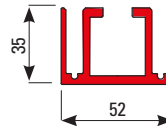

PA-310

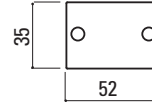

PA-311

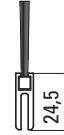

PA-214

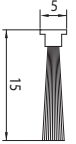

PA-632

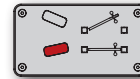
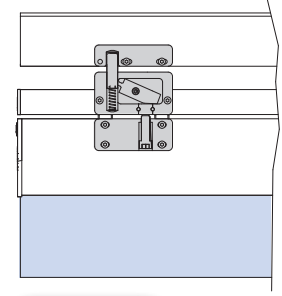
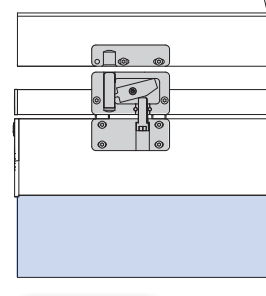
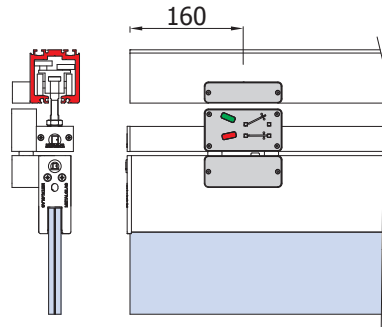
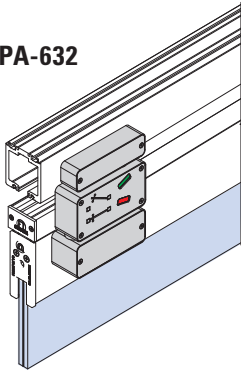

Anta scorrevole
Sliding door

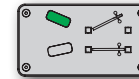

Porta battente
Pivot door

xme527c / xme527e

Sliding

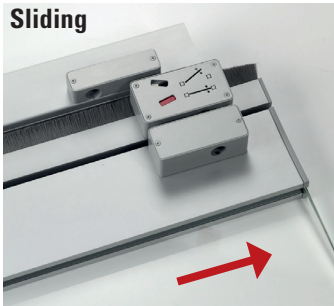



PA-300 PARK LINE 2

COME USARE MY METALGLAS / HOW TO USE MY METALGLAS / WIE MAN BENUTZT MY METALGLAS

1

INSERIRE LE MISURE DEL TUO VANO E LE ANTE DESIDERATE
ENTER THE MEASUREMENTS OF YOUR OPENING AND THE DOORS YOU REQUIRE
GEBEN SIE DIE MASSE IHRER ÖFFNUNG EIN UND DIE ERFORDERLICHEN TÜREN

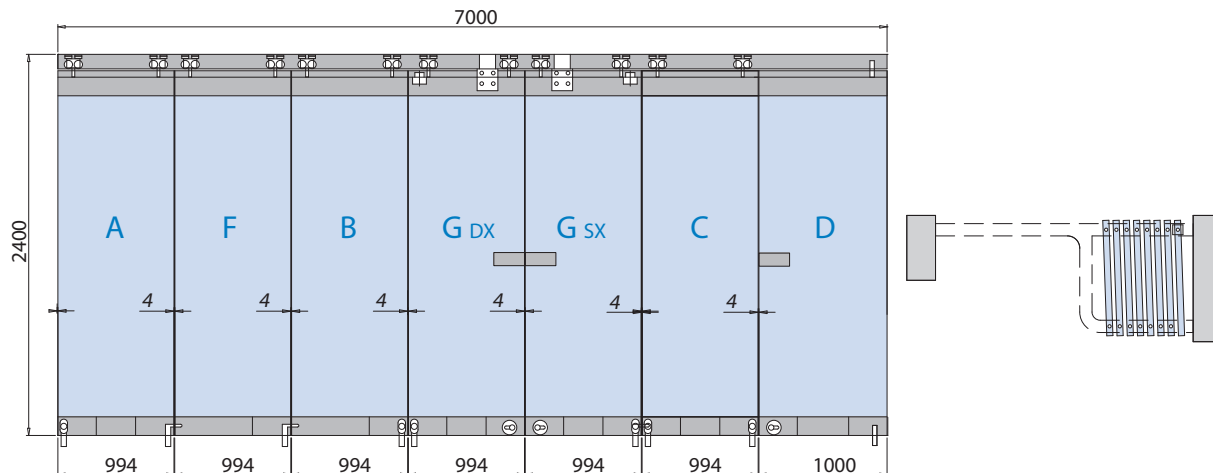

SCORREVOLI A PARCHEGGIO
SLIDING STACKING SYSTEMS

2

SI OTTENGONO LE MISURE DEI VETRI AUTOMATICAMENTE
THE MEASUREMENTS OF THE GLASS WILL BE GENERATED AUTOMATICALLY
DIE ABMESSUNGEN DES GLASES WERDEN AUTOMATISCH BERECHNET

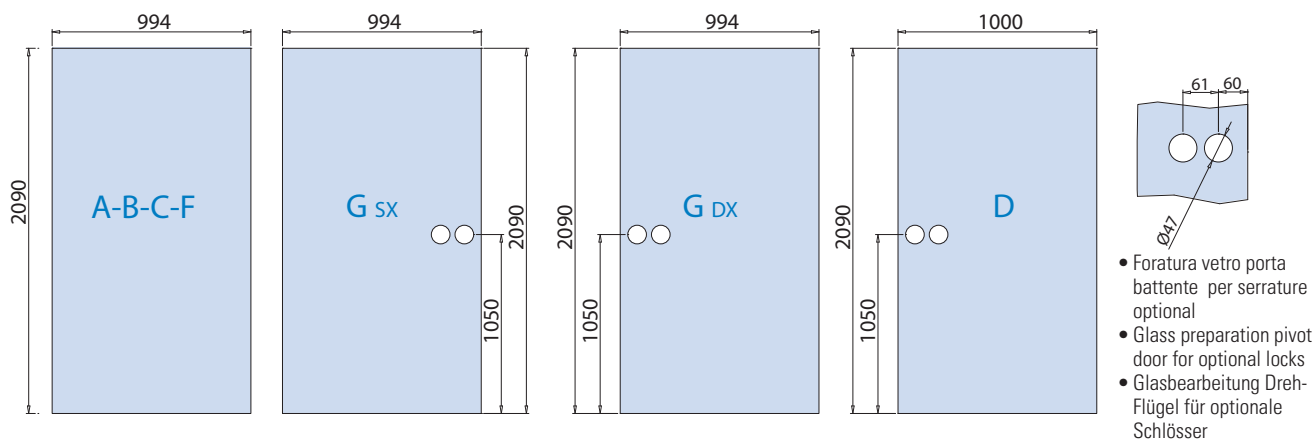

3

SI OTTENGONO LE DISTINTE DI TAGLIO DEI PROFILI, DA ABBINARE AGLI ACCESSORI
THE CUTTING SPECIFICATIONS OF THE PROFILES ARE OBTAINED, FOR MATCHING WITH THE ACCESSORIES
SIE ERHALTEN EINE SPEZIFIKATION DER PROFILLÄNGEN ZUM ABGLEICHEN MIT DEM ZUBEHÖR

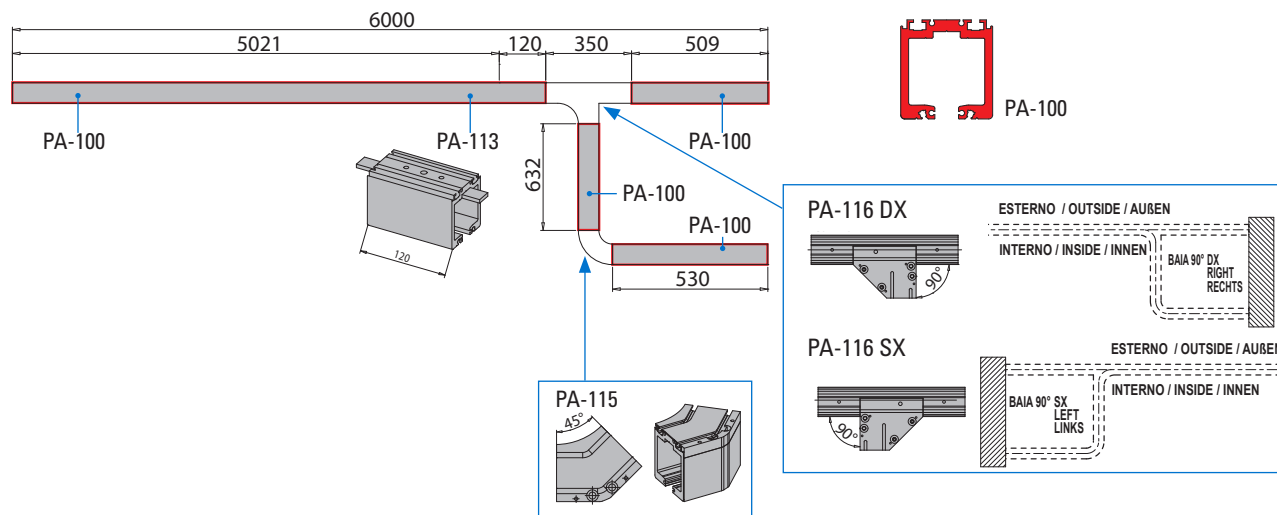

PA-300 PARK LINE 2

COME ASSEMBLARE LE ANTE / HOW TO ASSEMBLE THE DOORS / WIE DIE TÜREN ZUSAMMENGESETZT WERDEN

TAGLIO PROFILI PROFIL PREPARATION / PROFILBEARBEITUNG		KIT ACCESSORI ACCESSORY SETS / ZUBEHÖR SETS		ANTA COMPLETA COMPLETE DOOR / KOMPLETTE TÜR
--	--	--	--	--

ANTA A / DOOR A / TÜR A

PA-209 (x 2) PA-308 (x 1) PA-210 (x 4) PA-311 (x 2)

SUPERIORE / TOP / OBEN

986

102

PA-209 / PA-308 / PA-311

INFERIORE / BOTTOM / UNTEN

986

250 486 250

102

PA-225 + PA-203-POM PA-209 PA-225 + PA-202-PERN

- Lavorazione veletta con PA-225 + PA-203-POM
- Cover profile preparation with PA-225 + PA-203-POM
- Vorbereitung der Abdeckung mit PA-225 + PA-203-POM

14

37 37

INTERNO SX

61

PA-300 ANTA A-10 (for glass 10 mm)
PA-300 ANTA A-12 (for glass 12 - 12,7 mm)
 PRIMA ANTA A
 FIRST PANEL A
 ERSTER SCHIEBEFLÜGEL A

PA-301 (x 2) PA-211 (x 3) PA-212 (x 1) PA-223 (x 20)

L-112-PA (optional x 2)

PA-225-10 (x 4) PA-214 (max 2,5 mt) PA-314 (max 2,5 mt) PA-310 (x 2)

PA-225-12 (x 4)

PA-225 + PA-202-PERN (x 1) PA-224 (x 8) PA-225 + PA-203-POM (x 1)

250 mm 250 mm

PA-301 PA-301

PA-310 PA-211 PA-211 PA-211

PA-308 PA-311 (x 2)

PA-209 PA-210 (x 2) PA-211 PA-212 PA-210 (x 2) PA-209

PA-225 + PA-203-POM PA-225 + PA-202-PERN

SCORREVOLI A PARCHEGGIO
SLIDING STACKING SYSTEMS

ANTA B / DOOR B / TÜR B

PA-209 (x 2) PA-308 (x 1) PA-210 (x 4) PA-311 (x 2)

SUPERIORE / TOP / OBEN

986

102

PA-209 / PA-308 / PA-311

INFERIORE / BOTTOM / UNTEN

986

736 250

102

PA-209 PA-225 + PA-203-POM

- Lavorazione veletta con PA-225 + PA-203-POM
- Cover profile preparation with PA-225 + PA-203-POM
- Vorbereitung der Abdeckung mit PA-225 + PA-203-POM

14

37 37

INTERNO SX

61

PA-300 ANTA B-10 (for glass 10 mm)
PA-300 ANTA B-12 (for glass 12 - 12,7 mm)
 ULTIMA ANTA B
 LAST PANEL B
 END-SCHIEBEFLÜGEL B

PA-301 (x 2) PA-211 (x 3) PA-212 (x 1) PA-223 (x 20)

L-112-PA (optional x 2)

PA-225-10 (x 4) PA-214 (max 2,5 mt) PA-314 (max 2,5 mt) PA-310 (x 2)

PA-225-12 (x 4)

PA-225 + PA-203-POM (x 1) PA-224 (x 4)

250 mm

PA-301 PA-301

PA-310 PA-211 PA-211 PA-211

PA-308 PA-311 (x 2)

PA-209 PA-210 (x 2) PA-211 PA-212 PA-210 (x 2) PA-209

PA-225 + PA-203-POM

ANTA F / DOOR F / TÜR F

PA-209 (x 2) PA-308 (x 1) PA-210 (x 4) PA-311 (x 2)

SUPERIORE / TOP / OBEN

986

102

PA-209 / PA-309 / PA-311

INFERIORE / BOTTOM / UNTEN

986

736 250

102

PA-209 PA-225 + PA-202-PERN

PA-300 ANTA F-10 (for glass 10 mm)
PA-300 ANTA F-12 (for glass 12 - 12,7 mm)
 ANTA INTERMEDIA F
 INTERMEDIATE PANEL F / ZWISCHEN-SCHIEBEFLÜGEL F

PA-301 (x 2) PA-211 (x 3) PA-212 (x 1) PA-223 (x 20)

L-112-PA (optional x 1)

PA-225-10 (x 4) PA-214 (max 2,5 mt) PA-314 (max 2,5 mt) PA-310 (x 2)

PA-225-12 (x 4)

PA-225 + PA-202-PERN (x 1) PA-224 (x 4)

250 mm

PA-301 PA-301

PA-310 PA-211 PA-211 PA-211

PA-308 PA-311 (x 2)

PA-209 PA-210 (x 2) PA-211 PA-212 PA-210 (x 2) PA-209

PA-225 + PA-202-PERN

PA-300 PARK LINE 2

COME ASSEMBLARE LE ANTE / HOW TO ASSEMBLE THE DOORS / WIE DIE TÜREN ZUSAMMENSETZT WERDEN

TAGLIO PROFILI
PROFIL PREPARATION / PROFILBEARBEITUNG



KIT ACCESSORI
ACCESSORY SETS / ZUBEHÖR SETS



ANTA COMPLETA
COMPLETE DOOR / KOMPLETTE TÜR

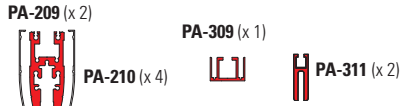

SUPERIORE / TOP / OBEN

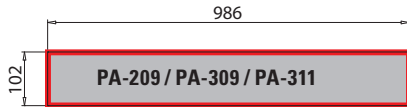

INFERIORE / BOTTOM / UNTEN

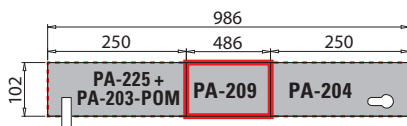

- Lavorazione veletta PA-210 con PA-204 e PA-225 + PA-203-POM
- Cover profile preparation PA-210 with PA-204 and PA-225 + PA-203-POM
- Vorbereitung der Abdeckung PA-210 mit PA-204 und PA-225 + PA-203-POM

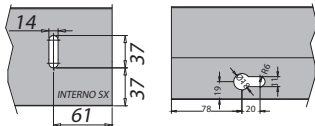

PA-300 ANTA G-10 (for glass 10 mm)
PA-300 ANTA G-12 (for glass 12 - 12,7 mm)
PORTA CENTRALE SCORREVOLE G
CENTRAL SLIDING PIVOTED DOOR G
DREH/PENDEL SCHIEBEFLÜGEL G

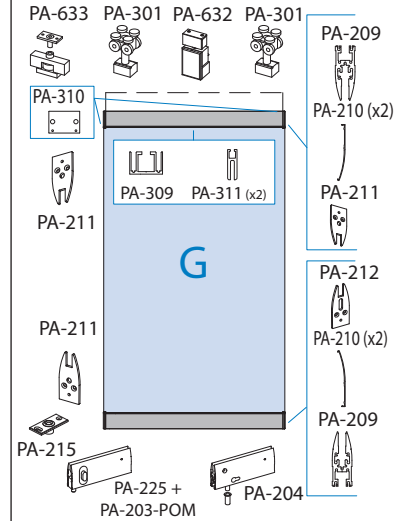
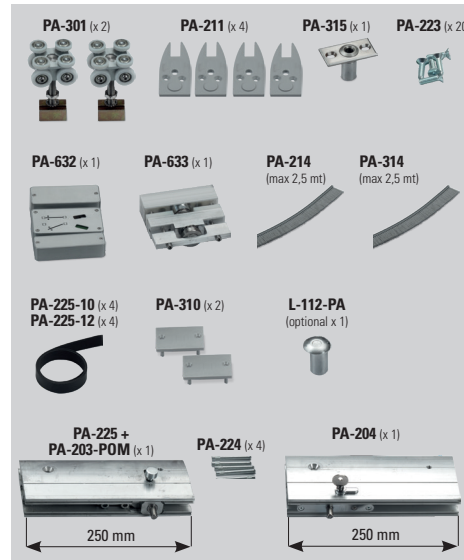

ANTA G / DOOR G / TÜR G

- Lavorazione profili PA-209 / PA-309
- Profiles preparation PA-209 / PA-309
- Vorbereitung der Profile PA-209 / PA-309

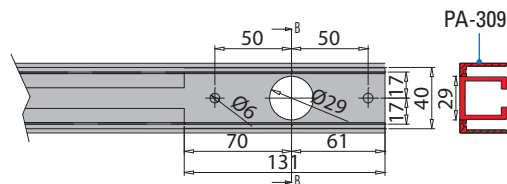
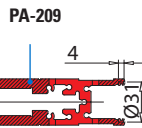
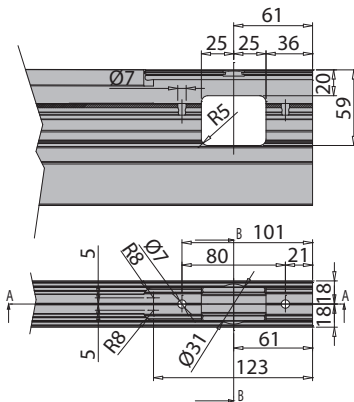

ANTA C / DOOR C / TÜR C

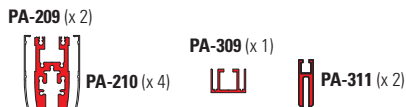

SUPERIORE / TOP / OBEN

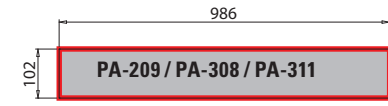

INFERIORE / BOTTOM / UNTEN

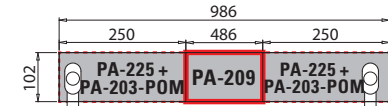

- Lavorazione veletta con PA-225 + PA-203-POM
- Cover profile preparation with PA-225 + PA-203-POM
- Vorbereitung der Abdeckung mit PA-225 + PA-203-POM

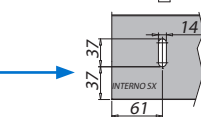

PA-300 ANTA C-10 (for glass 10 mm)
PA-300 ANTA C-12 (for glass 12 - 12,7 mm)
ANTA INTERMEDIA 2 C
INTERMEDIATE PANEL 2 C
ZWISCHEN-SCHIEBEFLÜGEL 2 C

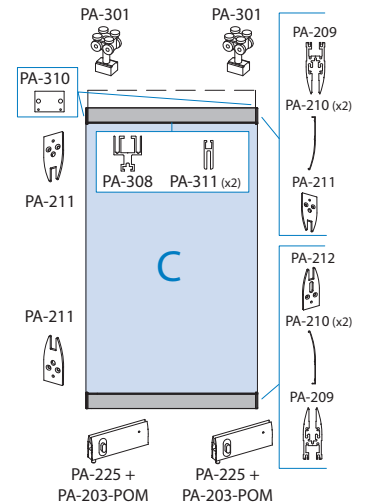
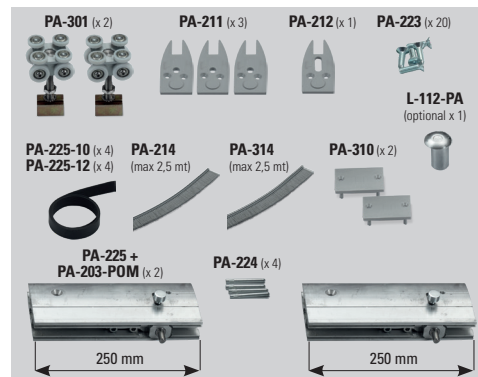

PA-300 PARK LINE 2

COME ASSEMBLARE LE ANTE / HOW TO ASSEMBLE THE DOORS / WIE DIE TÜREN ZUSAMMENSETZT WERDEN

TAGLIO PROFILI PROFIL PREPARATION / PROFILBEARBEITUNG	+ KIT ACCESSORI ACCESSORY SETS / ZUBEHÖR SETS	= ANTA COMPLETA COMPLETE DOOR / KOMPLETTE TÜR
<p>PA-209 (x 2) PA-210 (x 4) PA-308 (x 1) PA-311 (x 2)</p> <p>SUPERIORE / TOP / OBEN 986 102 PA-209 / PA-308 / PA-311</p> <p>INFERIORE / BOTTOM / UNTEN 986 250 736 102 PA-204 PA-209</p> <ul style="list-style-type: none"> Lavorazione veletta PA-210 con PA-204 Cover profile preparation PA-210 with PA-204 Vorbereitung der Abdeckung PA-210 mit PA-204 	<p>PA-300 ANTA D-10 (for glass 10 mm) PA-300 ANTA D-12 (for glass 12 - 12,7 mm) PORTA LATERALE D LATERAL PIVOT DOOR D DREH-SCHIEBEFLÜGEL D</p> <p>PA-205 (x 1) PA-211 (x 4) PA-223 (x 20) PA-225-10 (x 4) PA-225-12 (x 4) PA-214 (max 2,5 mt) PA-314 (max 2,5 mt) PA-310 (x 2) PA-204 (x 1) PA-224 (x 4) PA-206 (x 1) L-112-PA (optional x 1)</p>	<p>PA-305 PA-310 PA-211 PA-211 PA-211 PA-204 PA-206</p> <p>PA-209 PA-210 (x2) PA-211 PA-212 PA-210 (x2) PA-209</p> <p>xme540-a</p>

 SCORREVOLI A PARCHEGGIO
SLIDING STACKING SYSTEMS
