

B-5040 KAMPIONA DRAIN **NEW**

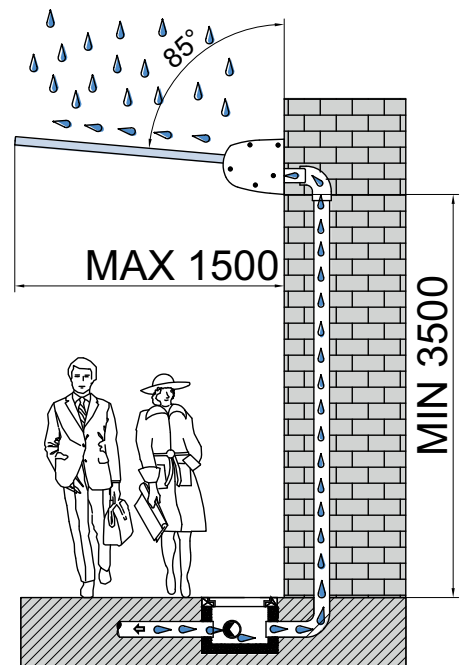



- L'acqua non aspetta e non si ferma mai. Cambia forma e scorre attorno alle cose. METALGLAS con Kampiona Drain ha trovato per lei sentieri a cui nessun altro aveva mai pensato.
- Water doesn't wait and is never static. It changes shape and flows around things. Metalglas with Kampiona Drain has found paths for it that no-one else had ever thought of.
- Wasser wartet nicht und bleibt nie stehen. Es nimmt unterschiedliche Formen an und fließt um die Dinge herum. Metalglas hat mit Kampiona Drain Wege gefunden, an die nie jemand anderes gedacht hatte.



B-5040 KAMPIONA DRAIN

NEW

NO Patent Pending

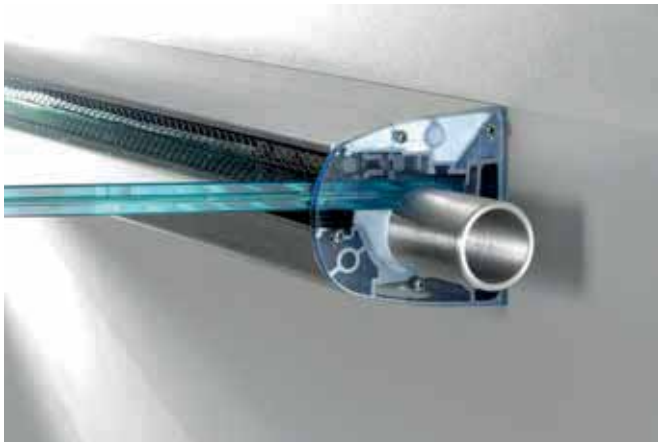

B-5040-SL
 SCARICO LATERALE
 LATERAL DRAIN / SEITLICHER ABFLUSS

B-5040-SI
 SCARICO INFERIORE
 LOWER DRAIN / UNTERER ABFLUSS

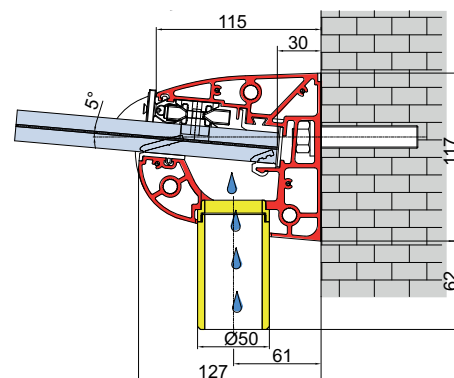
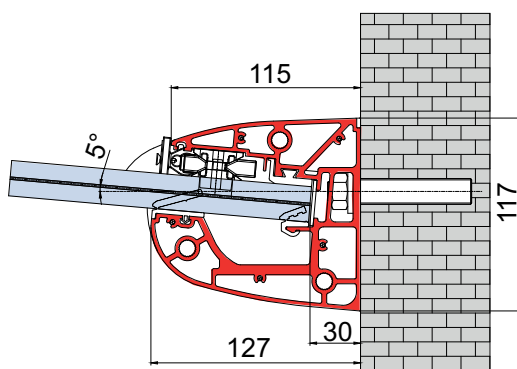
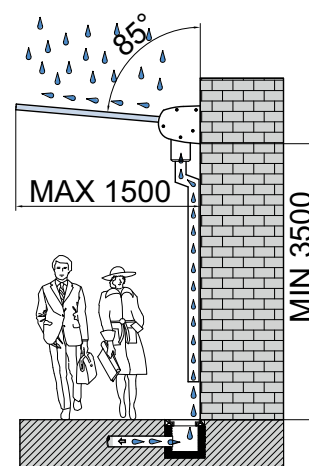
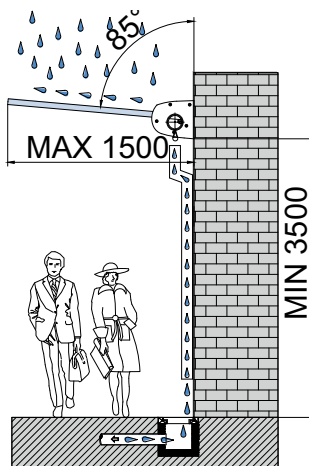
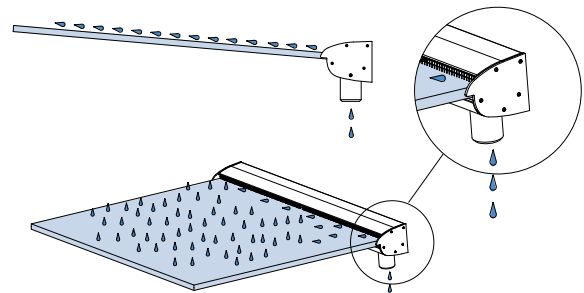
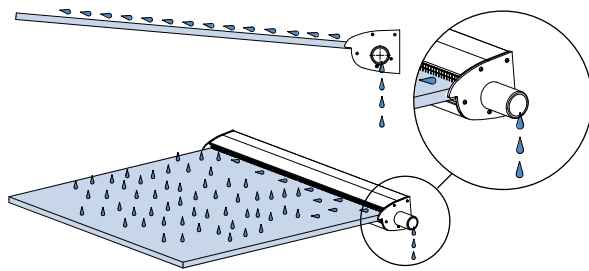

PENSILINE



B-5040-SP
SCARICO POSTERIORE
REAR DRAIN / RÜCKSEITIGER ABFLUSS

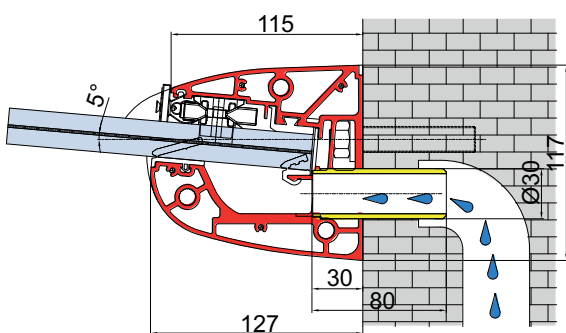
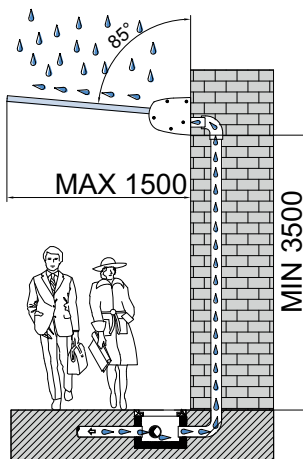
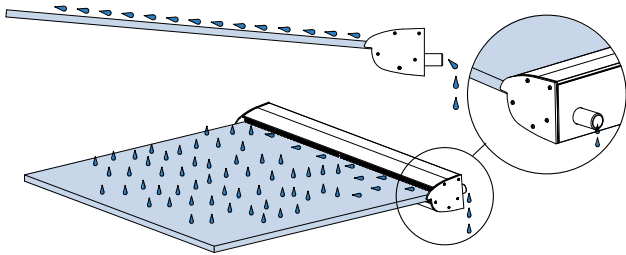

B-5040-M
MODULARE
MODULAR / MODULAR

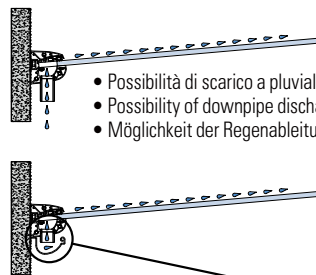
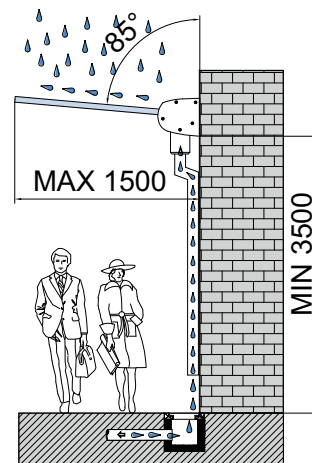
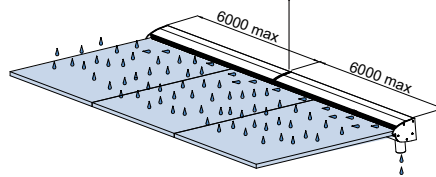
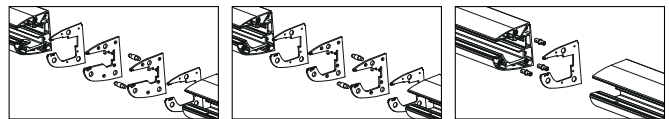

- Possibilità di scarico a pluviale con relativi scoli
- Possibility of downpipe discharge with relative drains
- Möglichkeit der Regenableitung mit entsprechenden Leisten

- Possibilità di scarico a grondaia con relativi scoli
- Possibility of gutter discharge with relative drains
- Möglichkeit der Ableitung über Dachrinne mit entsprechenden Leisten

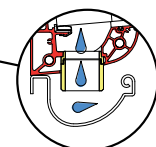

B-5040-SL KAMPIONA DRAIN

SCARICO LATERALE / LATERAL DRAIN / SEITLICHER ABFLUSS

€▶H.279 → €▶H.285

NEW

NO
PENDING

Patent
Pending

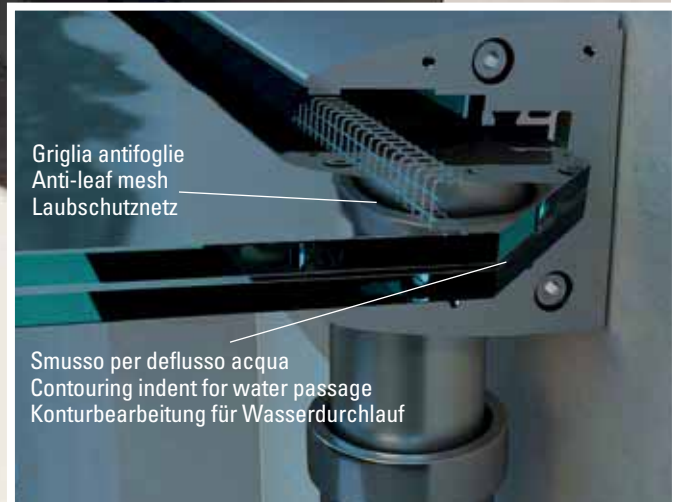
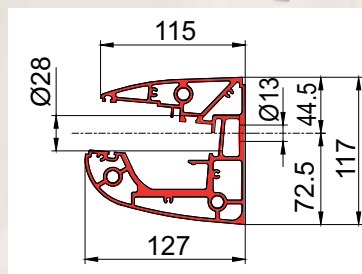

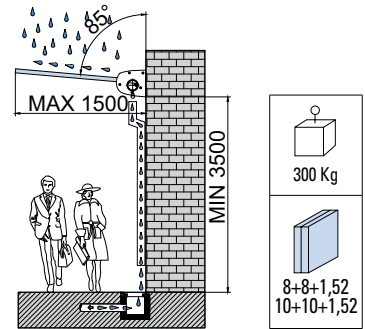
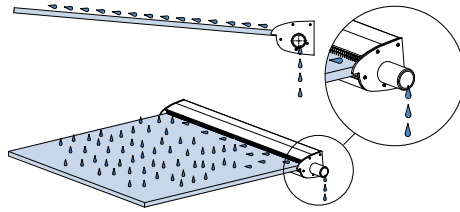
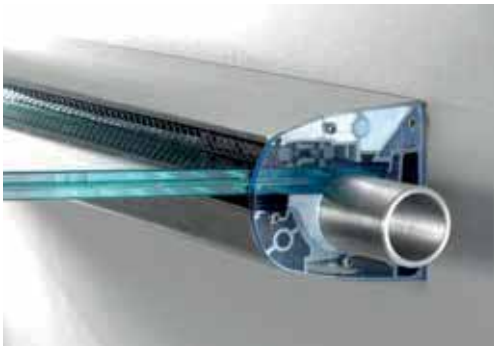

SET (TAPPI LATERALI E SCARICHI ACQUA ESCLUSI)

SET (ENDCAPS AND DRAIN NOT INCLUDED)

SET (ENDKAPPEN UND ABFLUSS NICHT ENTHALTEN)

B-5040 set 1

L=1500 mm
con/with/mit
3 Jolly Pack

N. 3 pcs

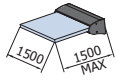

B-5040 set 2

L=2000 mm
con/with/mit
4 Jolly Pack

N. 4 pcs

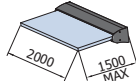

B-5040set 3

L=3000 mm
con/with/mit
6 Jolly Pack

N. 6 pcs

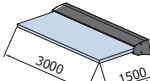

B-5040 set 4

L=4000 mm
con/with/mit
8 Jolly Pack

N. 8 pcs

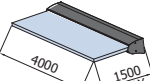

B-5040 set 6

L=6000 mm
con/with/mit
12 Jolly Pack

12 pcs

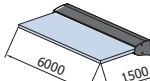

B-5040 set MIS

- Tagliato a misura cliente
- Custom length
- Nach Mass geschnitten

N. 2-8 pcs

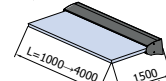

SET B-5040 CON SCARICO LATERALE B-5040-SL

SET B-5040 WITH LATERAL DRAIN B-5040-SL

SET B-5040 MIT SEITLICHER ABFLUSS B-5040-SL

- Griglia antifoglie
- Anti-leaf mesh
- Laubschutznetz

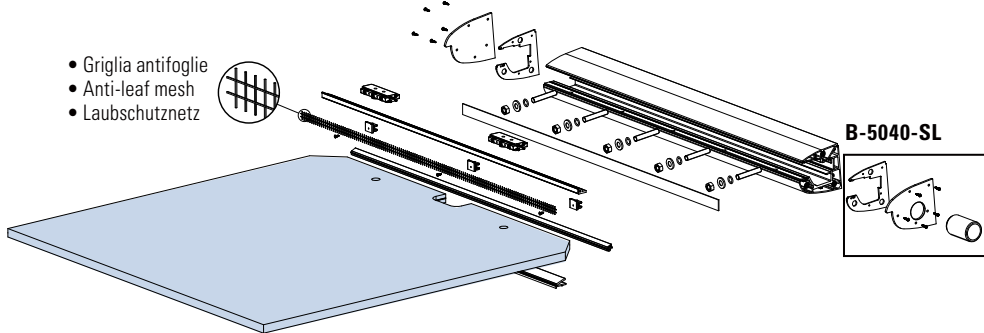

B-5040-SL

B-5040-SL

- Tappo con scarico laterale e tappo cieco con guarnizioni.
- Endcap with lateral drain and blind endcaps with gaskets.
- Endkappe mit seitlichen Abfluss und geschlossene Endkappe mit Dichtungen.

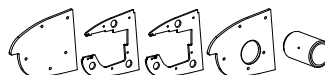

Quota variabile / Variable size / Variables Maß

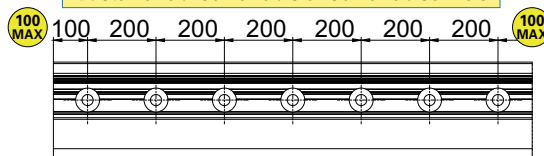

- Sede per LED 18x5 max, per illuminazione vetro
- Channel for LED, for glass lighting
- Sitz für LED, für Beleuchtung des Glas

- Lavorazione vetro. Solo la lastra superiore è forata.
- Glass preparation. Only the upper glass panel is drilled.
- Glasbearbeitung. Nur die obere Scheibe wird gebohrt.

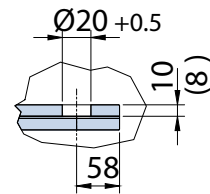

- Lavorazione vetro alternativa.
- Alternative glass preparation.
- Alternative Glasbearbeitung.

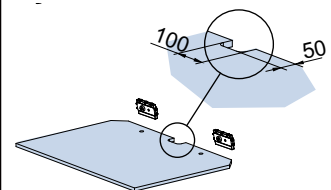
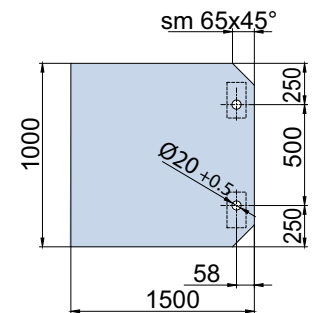
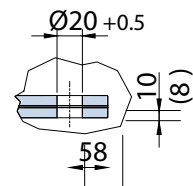

- Tasca opzionale per flusso acqua
- Optional cavity for water flow
- Optionale Tasche für Wasserfluss

xme558a

B-5040-SI KAMPIONA DRAIN

SCARICO INFERIORE / LOWER DRAIN / UNTERER ABFLUSS

€>H.279 → €>H.285

NEW

NO
Patent
Pending

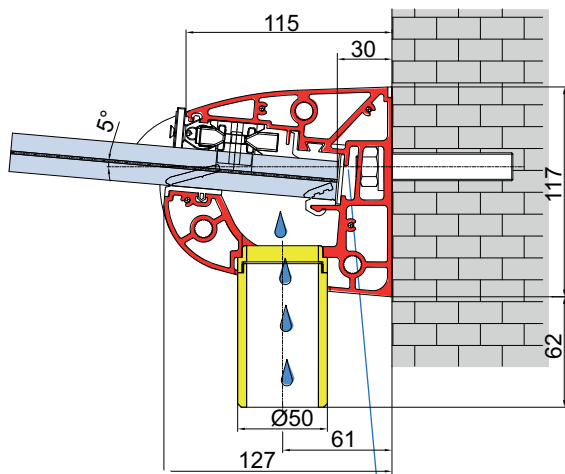

Griglia antifoglie
Anti-leaf mesh
Laubschutznetz

Smusso per deflusso acqua
Contouring indent for water passage
Konturbearbeitung für Wasserdurchlauf

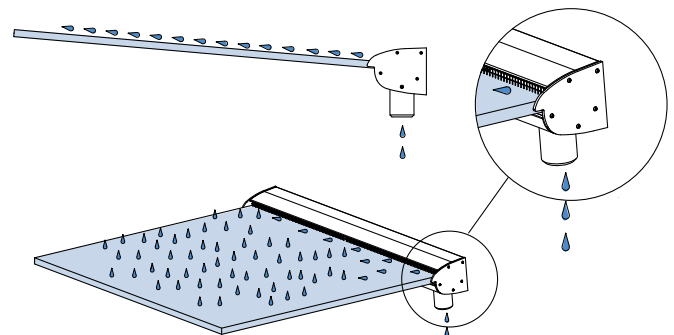

- Sede per LED 18x5 max, per illuminazione vetro
- Channel for LED, for glass lighting
- Sitz für LED, für Beleuchtung des Glas

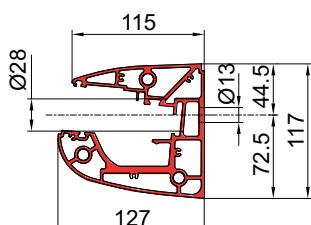

Quota variabile / Variable size / Variables Maß

100 MAX 100 200 200 200 200 200 200 100 MAX

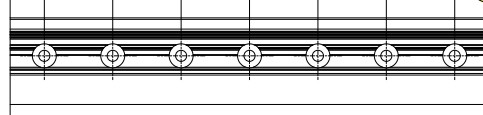

- Foratura per scarico inferiore
- Hole for low drain
- Bohrung für unteren Abfluss

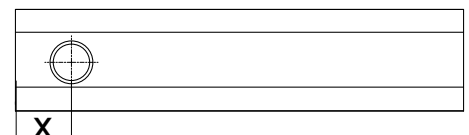

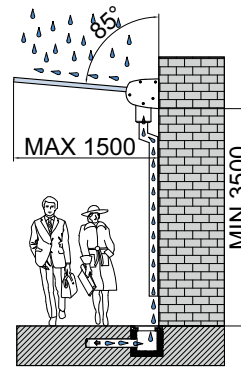

	300 Kg
	8+8+1,52 10+10+1,52

SET (TAPPI LATERALI E SCARICHI ACQUA ESCLUSI)

SET (ENDCAPS AND DRAIN NOT INCLUDED)

SET (ENDKAPPEN UND ABFLUSS NICHT ENTHALTEN)

B-5040 set 1

L=1500 mm
con/with/mit
3 Jolly Pack

N. 3 pcs

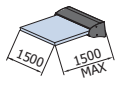

B-5040 set 2

L=2000 mm
con/with/mit
4 Jolly Pack

N. 4 pcs

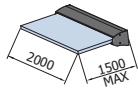

B-5040set 3

L=3000 mm
con/with/mit
6 Jolly Pack

N. 6 pcs

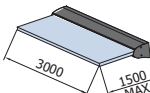

B-5040 set 4

L=4000 mm
con/with/mit
8 Jolly Pack

N. 8 pcs

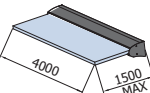

B-5040 set 6

L=6000 mm
con/with/mit
12 Jolly Pack

12 pcs

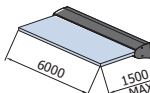

B-5040 set MIS

- Tagliato a misura cliente
- Custom length
- Nach Mass geschnitten

N. 2-8 pcs

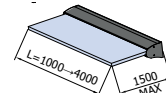

SET B-5040 CON SCARICO INFERIORE B-5040-SI

SET B-5040 WITH LATERAL DRAIN B-5040-SI

SET B-5040 MIT SEITLICHER ABFLUSS B-5040-SI

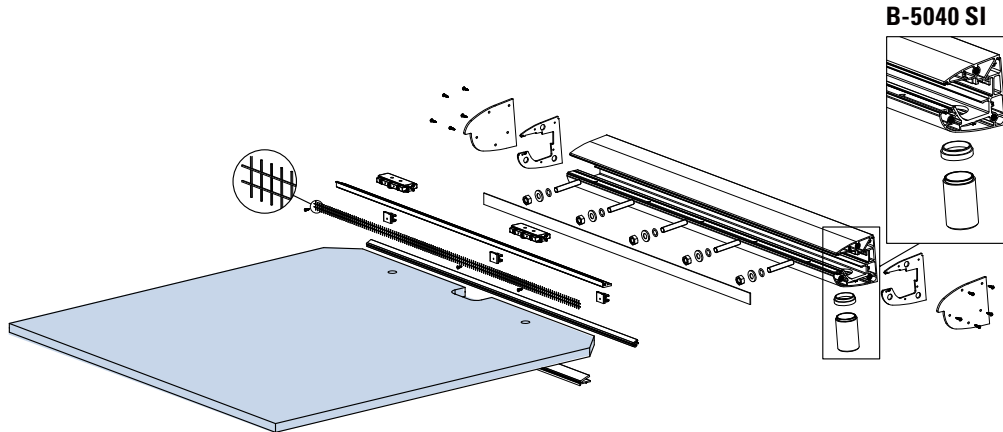

B-5040 SI

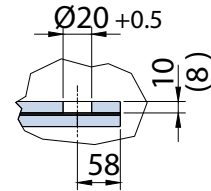
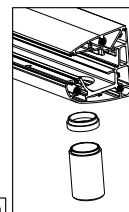

- Lavorazione vetro alternativa.
- Alternative glass preparation.
- Alternative Glasbearbeitung.

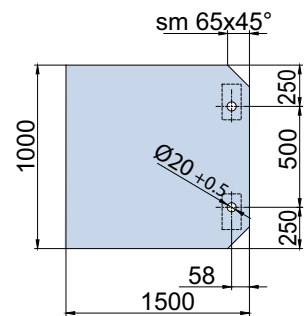
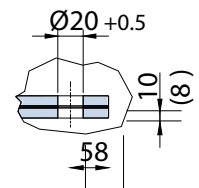

LAV-5040-SI

- Foratura scarico inferiore fatta su profilo intero a C.N.C.
- Tubo di scarico e tappi esclusi.
- Holes for low drain created on entire profile via C.N.C.
- Drain pipe and endcaps not included.
- Bohrung für unteren Abfluss am CNC-gefrästen Innenprofil.
- Abflussrohr und Endkappen nicht enthalten.

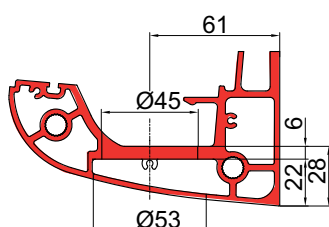
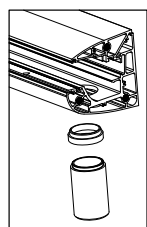

B-5040 SI

- Tappi ciechi con guarnizioni e scarico acqua inferiore.
- Blind encaps with gaskets and lower drain pipe.
- Geschlossen Endkappen mit Dichtungen und unteres Abflussrohr.

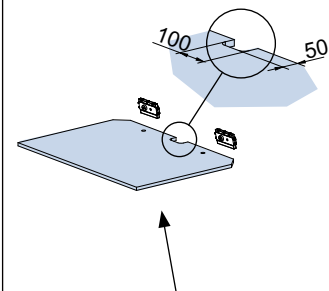
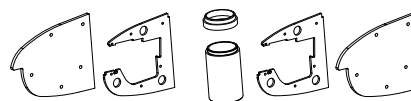

- Tasca opzionale per flusso acqua
- Optional cavity for water flow
- Optionale Tasche für Wasserfluss

xme558b

B-5040-SP KAMPIONA DRAIN

SCARICO POSTERIORE / REAR DRAIN / RÜCKSEITIGER ABFLUSS

€>H.279 → €>H.285

NEW **NO** Patent Pending

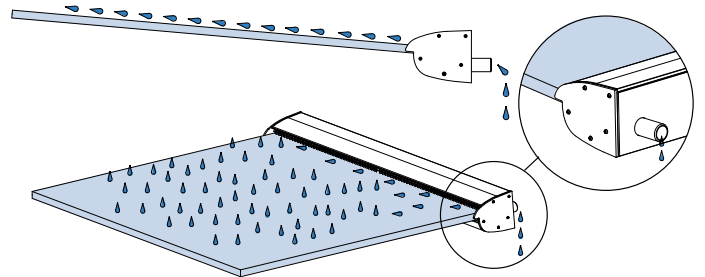
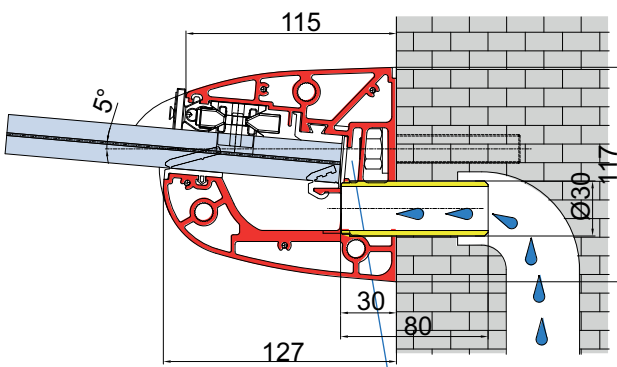

- Sede per LED 18x5 max, per illuminazione vetro
- Channel for LED, for glass lighting
- Sitz für LED, für Beleuchtung des Glas

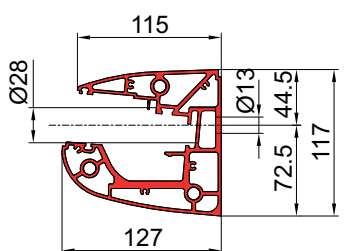

Quota variabile / Variable size / Variables Maß

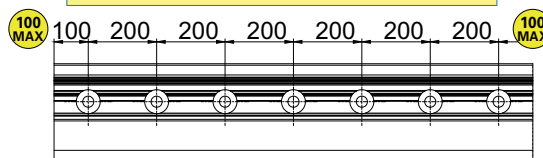

- Foratura per scarico posteriore
- Hole for rear drain
- Bohrung für rückseitiger Abfluss

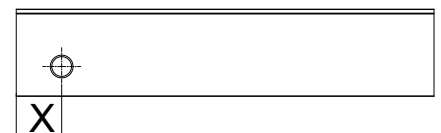

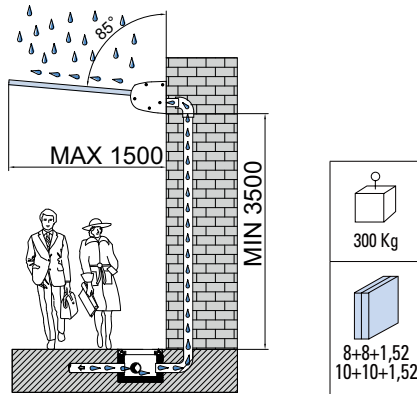

SET (TAPPI LATERALI E SCARICHI ACQUA ESCLUSI)

SET (ENDCAPS AND DRAIN NOT INCLUDED)

SET (ENDKAPPEN UND ABFLUSS NICHT ENTHALTEN)

B-5040 set 1

L=1500 mm
con/with/mit
3 Jolly Pack

N. 3 pcs

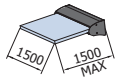

B-5040 set 2

L=2000 mm
con/with/mit
4 Jolly Pack

N. 4 pcs

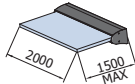

B-5040 set 3

L=3000 mm
con/with/mit
6 Jolly Pack

N. 6 pcs

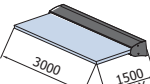

B-5040 set 4

L=4000 mm
con/with/mit
8 Jolly Pack

N. 8 pcs

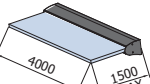

B-5040 set 6

L=6000 mm
con/with/mit
12 Jolly Pack

12 pcs

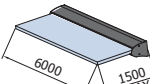

B-5040 set MIS

- Tagliato a misura cliente
- Custom length
- Nach Mass geschnitten

N. 2-8 pcs

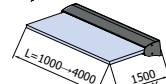

SET B-5040 CON SCARICO POSTERIORE B-5040-SP

SET B-5040 WITH REAR DRAIN B-5040-SP

SET B-5040 MIT RÜCKSEITIGER ABFLUSS B-5040-SP

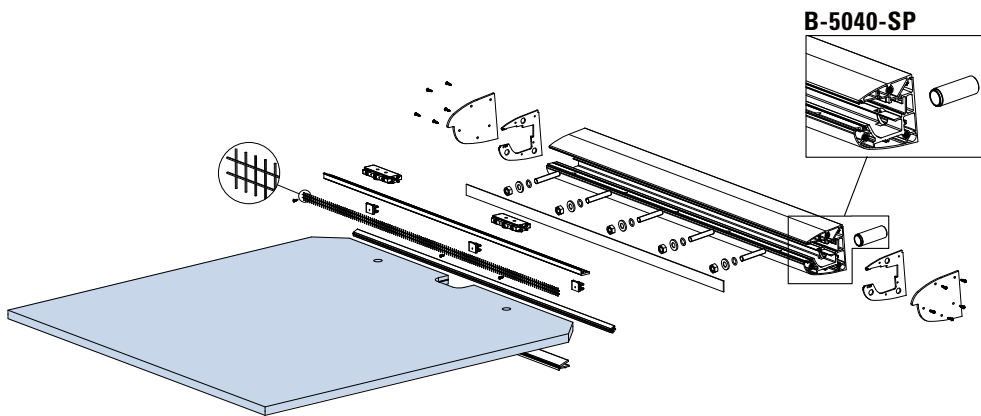

LAV-5040-SP

- Foratura scarico inferiore fatta su profilo intero a C.N.C.
- Tubo di scarico e tappi esclusi
- Holes for low drain created on entire profile via C.N.C.
- Drain pipe and endcaps not included
- Bohrung für unteren Abfluss am CNC-gefrästen Innenprofil.
- Abflussrohr und Endkappen nicht enthalten

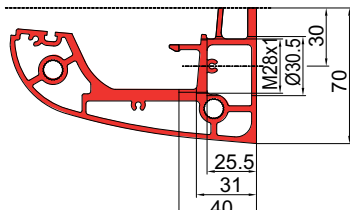
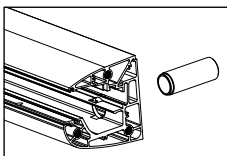

B-5040-SP

- Tappi ciechi con guarnizioni e scarico acqua posteriore
- Blind encaps with gaskets and rear drain pipe
- Geschlossen Endkappen mit Dichtungen und rückseitiger Abflussrohr

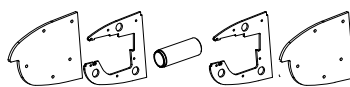

- Lavorazione vetro.
- Solo la lastra superiore è forata.
- Glass preparation.
- Only the upper glass panel is drilled.
- Glasbearbeitung.
- Nur die obere Scheibe wird gebohrt.

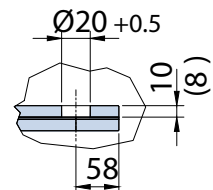

- Lavorazione vetro alternativa.
- Alternative glass preparation.
- Alternative Glasbearbeitung.

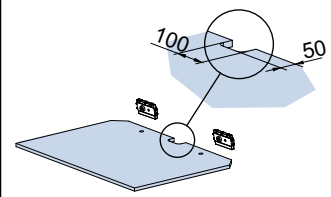
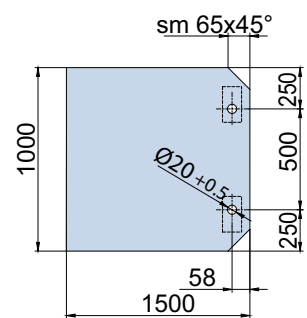
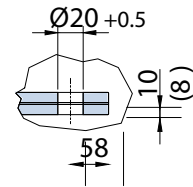

- Tasca opzionale per flusso acqua
- Optional cavity for water flow
- Optionale Tasche für Wasserfluss

xme558c

B-5040-M KAMPIONA DRAIN MODULARE / MODULAR / MODULAR

NEW



Patent Pending



- Sistema modulare con varie possibilità di connessione dei profili
- Modular system with different possibilities of connection
- Modulares System mit verschiedenen Möglichkeiten zum verbinden von Profilen

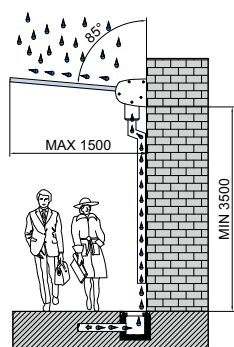

B-5049-TCH

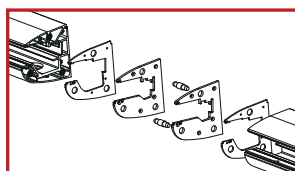

B-5049-TAG

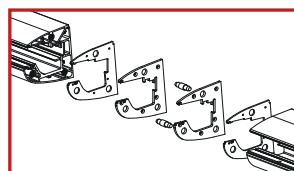

B-5049-INS-INT

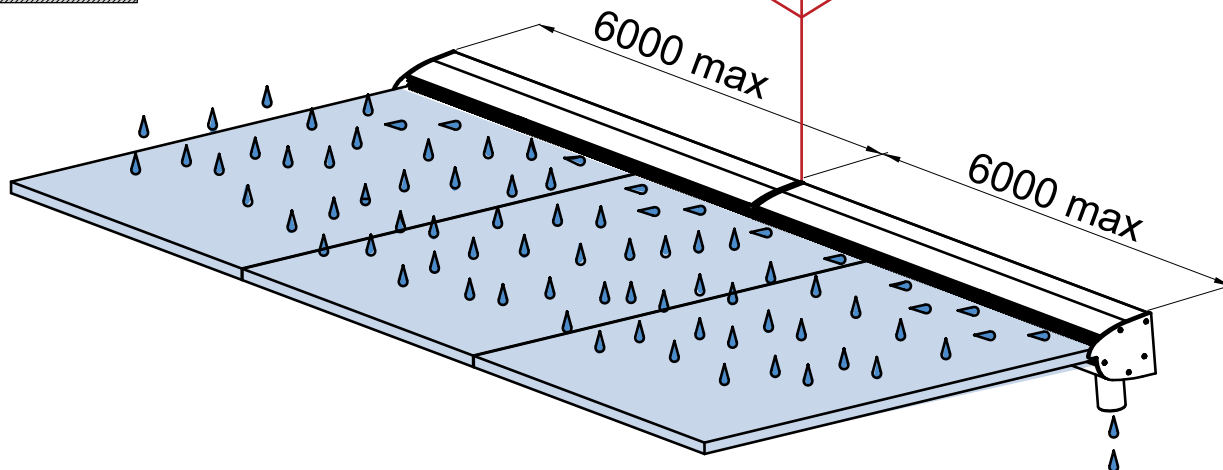
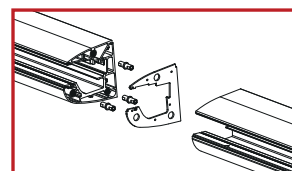

PENSILINA KAMPIONA MODULO TCH ▶ 142

Ogni modulo ha il suo scarico. Elementi indipendenti
 Each module has its own drain. Independent elements
 Jedes Modul hat seinen eigenen Abfluss. Unabhängige Elemente

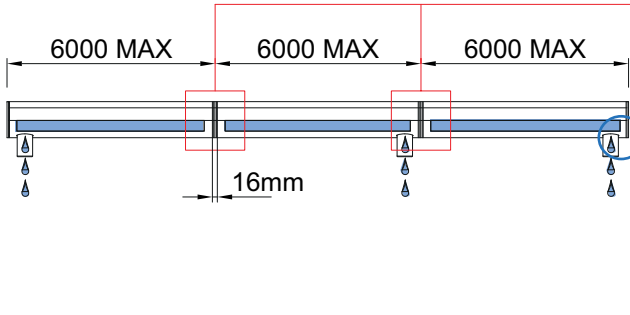

B-5048-SI

- TAPPO TCH
- TCH CAP
- TCH KAPPE

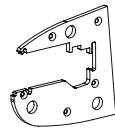

- INTERROMPE IL FLUSSO D'ACQUA
- CAP STOPS THE WATER DRAINAGE
- DIE KAPPE STOPT DEN WASSERFLUSS

B-5049-TCH

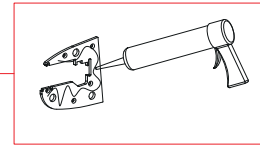
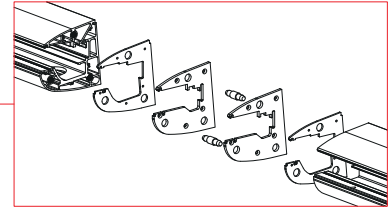

PENSILINA KAMPIONA MODULO TAG ▶ 142

Più moduli hanno lo stesso scarico. Elementi comunicanti
 Multiple modules have the same drain. Connecting elements
 Mehrere Module haben den selben Abfluss. Verbindungselemente

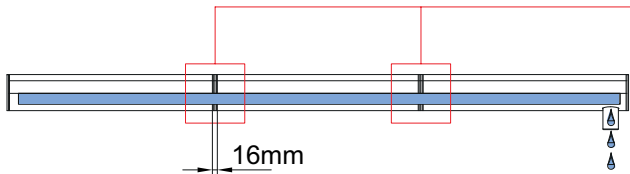

- TAPPO TAG
- TAG CAP
- TAG KAPPE

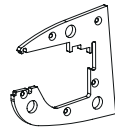

- FLUSSO D'ACQUA PASSANTE
- CAP ALLOWS THE WATER DRAINAGE
- DIE KAPPE ERMÖGLICHT DEN WASSERFLUSS

B-5049-TAG

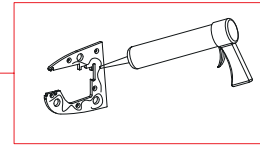
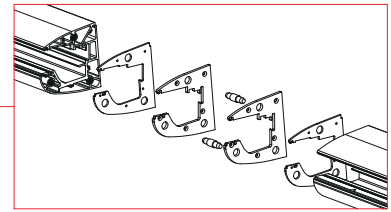

PENSILINA KAMPIONA MODULO CON TIRANTI ▶ 143

Più moduli hanno lo stesso scarico. Elementi comunicanti
 Multiple modules have the same drain. Connecting elements
 Mehrere Module haben den selben Abfluss. Verbindungselemente

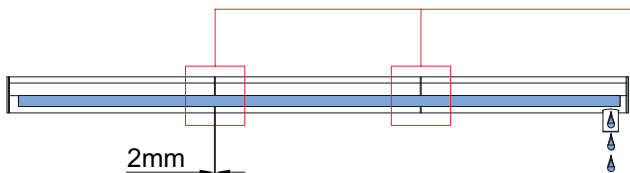

- SERRAGGIO MODULI TRAMITE TIRANTI FILETTATI
- BUNDLE CLOSURE THROUGH THREADED RODS
- PACKVERSCHLUSS DURCH GEWINDESTANGEN

- GUARNIZIONE TENUTA STAGNA
- WATERTIGHT SEAL
- WASSERDICHTER ABDICHTUNG

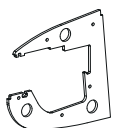

- FLUSSO D'ACQUA PASSANTE
- CAP ALLOWS THE WATER DRAINAGE
- DIE KAPPE ERMÖGLICHT DEN WASSERFLUSS

B-5049-INS-INT

- Giunti intermedi per tiranti SET 3 PCS + 1 guarnizione tenuta stagna
- Intermediate joints for tie rods SET 3 PCS + 1 watertight seal
- Zwischengelenke für Zugstangen SET 3 PCS + 1 wasserdichte Dichtung

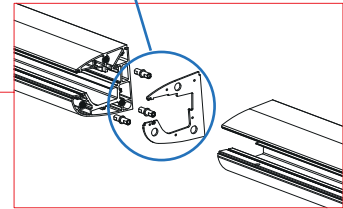

B-5049-TIR

- Barre tiranti M6x3000 mm SET 3 PCS. Tiranti per chiusura a pacco tenuta stagna
- M6x3000 mm tie rods SET 3 PCS. Tie rods for watertight bundle closure
- Zugstangen M6x3000 mm SET 3 STÜCK. Zugstangen für wasserdichten Packverschluss

B-5049-INS-FIN

- Inerti finali M6, set 6 pcs
- End inserts M6, set 6 pcs
- Endeinsätze M6, set 6 pcs

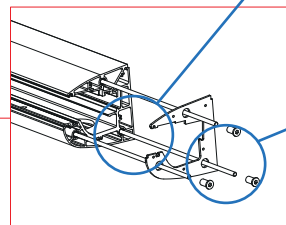

B-5040 KAMPIONA MODULO TCH

€▶H.283

Ogni modulo ha il suo scarico. Elementi indipendenti
Each module has its own drain. Independent elements
Jedes Modul hat seinen eigenen Abfluss. Unabhängige Elemente

B-5049-TCH

- 2 tappi chiusi + 2 guarnizioni + 2 spine
- 2 caps + 2 gaskets + 2 pins
- 2 Kappen + 2 Dichtungen + 2 Stifte

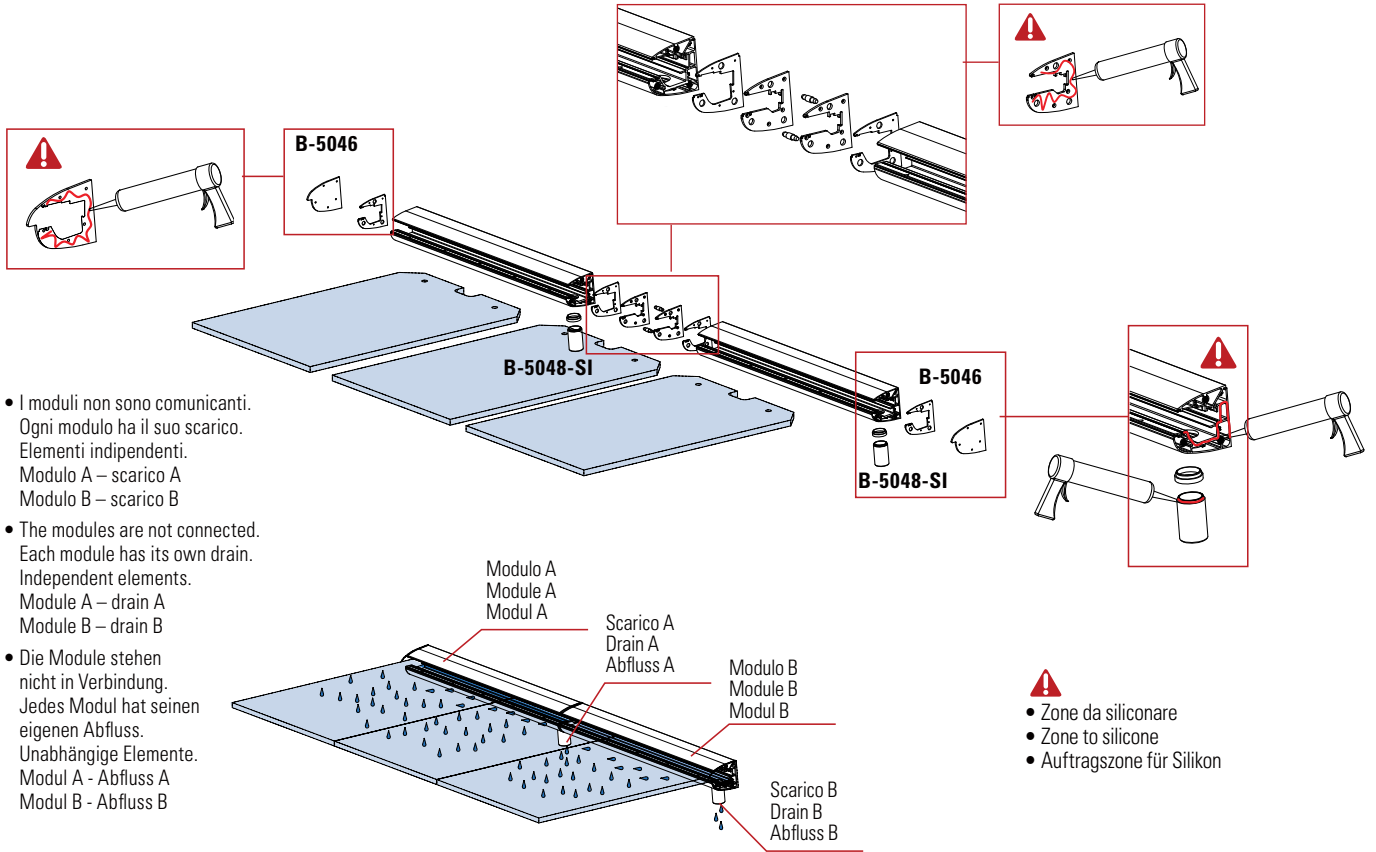

- I moduli non sono comunicanti. Ogni modulo ha il suo scarico. Elementi indipendenti. Modulo A – scarico A Modulo B – scarico B
- The modules are not connected. Each module has its own drain. Independent elements. Module A – drain A Module B – drain B
- Die Module stehen nicht in Verbindung. Jedes Modul hat seinen eigenen Abfluss. Unabhängige Elemente. Modul A - Abfluss A Modul B - Abfluss B

- ⚠
- Zone da siliconare
- Zone to silicone
- Auftragszone für Silikon

xme558o

B-5040 KAMPIONA MODULO TAG

€▶H.284

Più moduli hanno lo stesso scarico. Elementi comunicanti
Multiple modules have the same drain. Connecting elements
Mehrere Module haben den selben Abfluss. Verbindungselemente

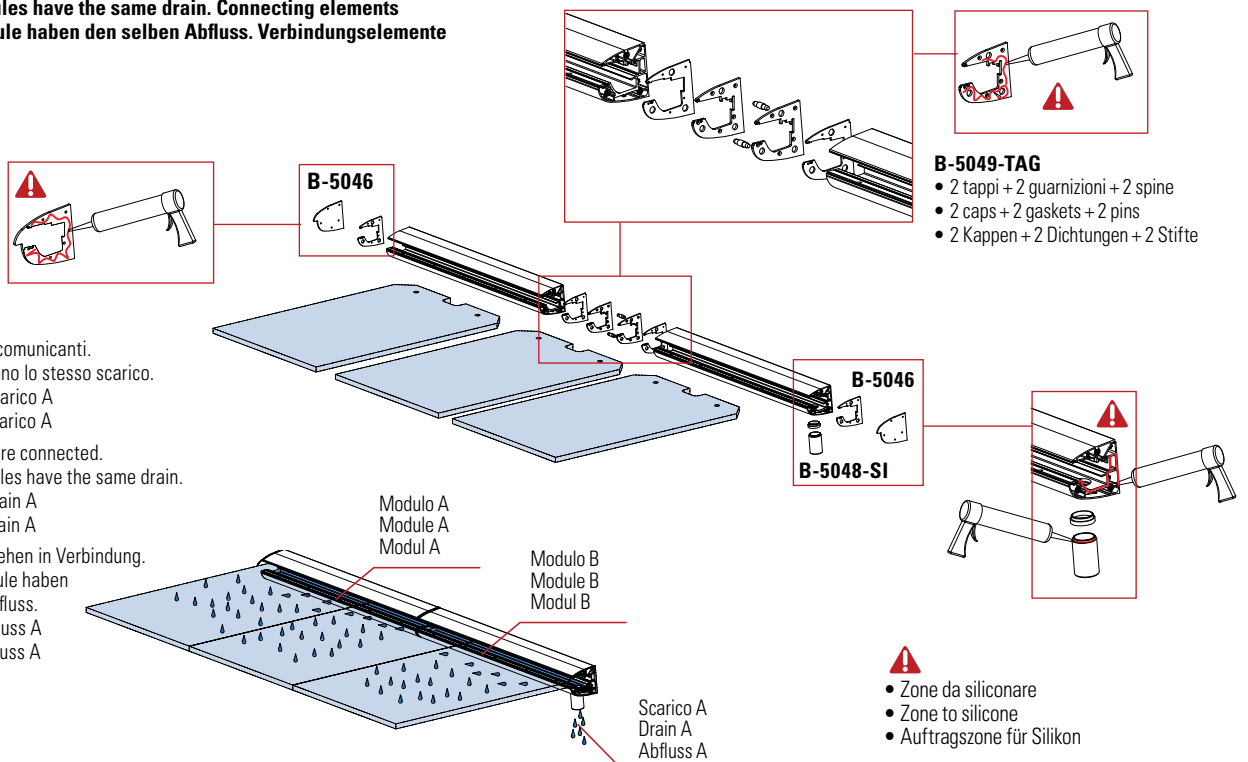

B-5049-TAG

- 2 tappi + 2 guarnizioni + 2 spine
- 2 caps + 2 gaskets + 2 pins
- 2 Kappen + 2 Dichtungen + 2 Stifte

- I moduli sono comunicanti. Più moduli hanno lo stesso scarico. Modulo A – scarico A Modulo B – scarico A
- The modules are connected. Multiple modules have the same drain. Module A – drain A Module B – drain A
- Die Module stehen in Verbindung. Mehrere Module haben den selben Abfluss. Modul A - Abfluss A Modul B - Abfluss A

- ⚠
- Zone da siliconare
- Zone to silicone
- Auftragszone für Silikon

xme558p

B-5040 KAMPIONA MODULO € H.285

CON TIRANTI / SOLUTION WITH TENSION RODS / MÖGLICHKEIT MIT ZUGSTANGEN

Più moduli hanno lo stesso scarico. Elementi comunicanti
Multiple modules have the same drain. Connecting elements
Mehrere Module haben den selben Abfluss. Verbindungselemente

B-5049-INS-INT

- Giunti intermedi per tiranti set 3 pcs + 1 guarnizione tenuta stagna
- Intermediate joints for tie rods set 3 pcs + 1 watertight seal
- Zwischengelenke für Zugstangen set 3 Stück + 1 wasserdichte Dichtung

B-5049-TIR

- Barre tiranti M6x3000 mm set 3 pcs. Tiranti per chiusura a pacco tenuta stagna
- M6x3000 mm tie rods set 3 pcs. Tie rods for watertight bundle closure
- Zugstangen M6x3000 mm set 3 Stück. Zugstangen für wasserdichten Packverschluss

B-5049-INS-FIN

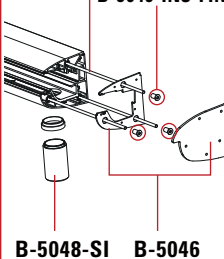

B-5048-SI B-5046

B-5049-INS-INT

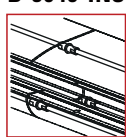

B-5049-GIUNTI

- Giunti per aste filettate, 3 pcs
- Joints for threaded rods
- Verbindungen für Gewindestangen

B-5046
Tappo + guarnizione

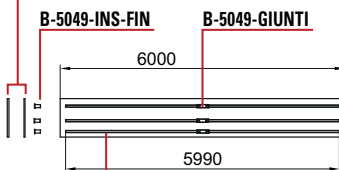

B-5049-TIR
Tiranti filettati

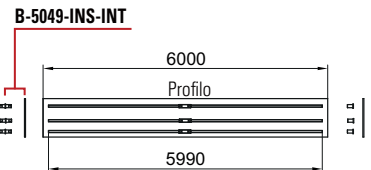

- Zone da siliconare
- Zone to silicone
- Auftragszone für Silikon

B-5049-INS-FIN

- Inserti finali M6, set 6 pcs
- End inserts M6, set 6 pcs
- Endeinsätze M6, set 6 pcs

- I moduli sono comunicanti. Più moduli hanno lo stesso scarico.
Modulo A – scarico A
Modulo B – scarico A
- The modules are connected. Multiple modules have the same drain.
Module A – drain A
Module B – drain A
- Die Module stehen in Verbindung. Mehrere Module haben den selben Abfluss.
Modul A - Abfluss A
Modul B - Abfluss A

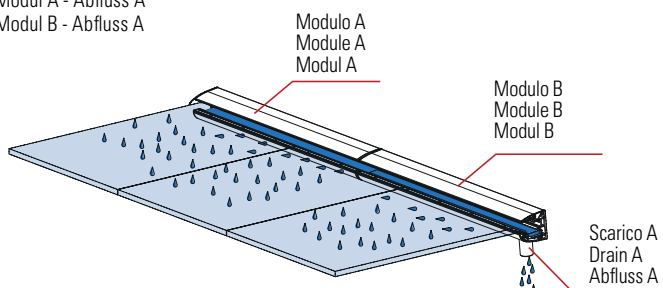

B-5046
Tappo + guarnizione

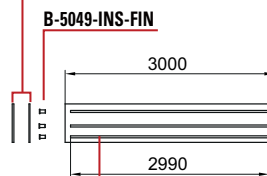

B-5049-TIR
Tiranti filettati

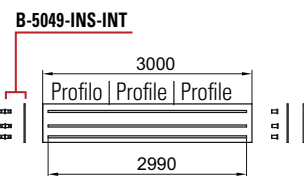

PENSILINA KAMPIONA DRAIN

DATI TECNICI / TECHNICAL DATA / TECHNISCHE DATEN

NEW

ND

Patent Pending

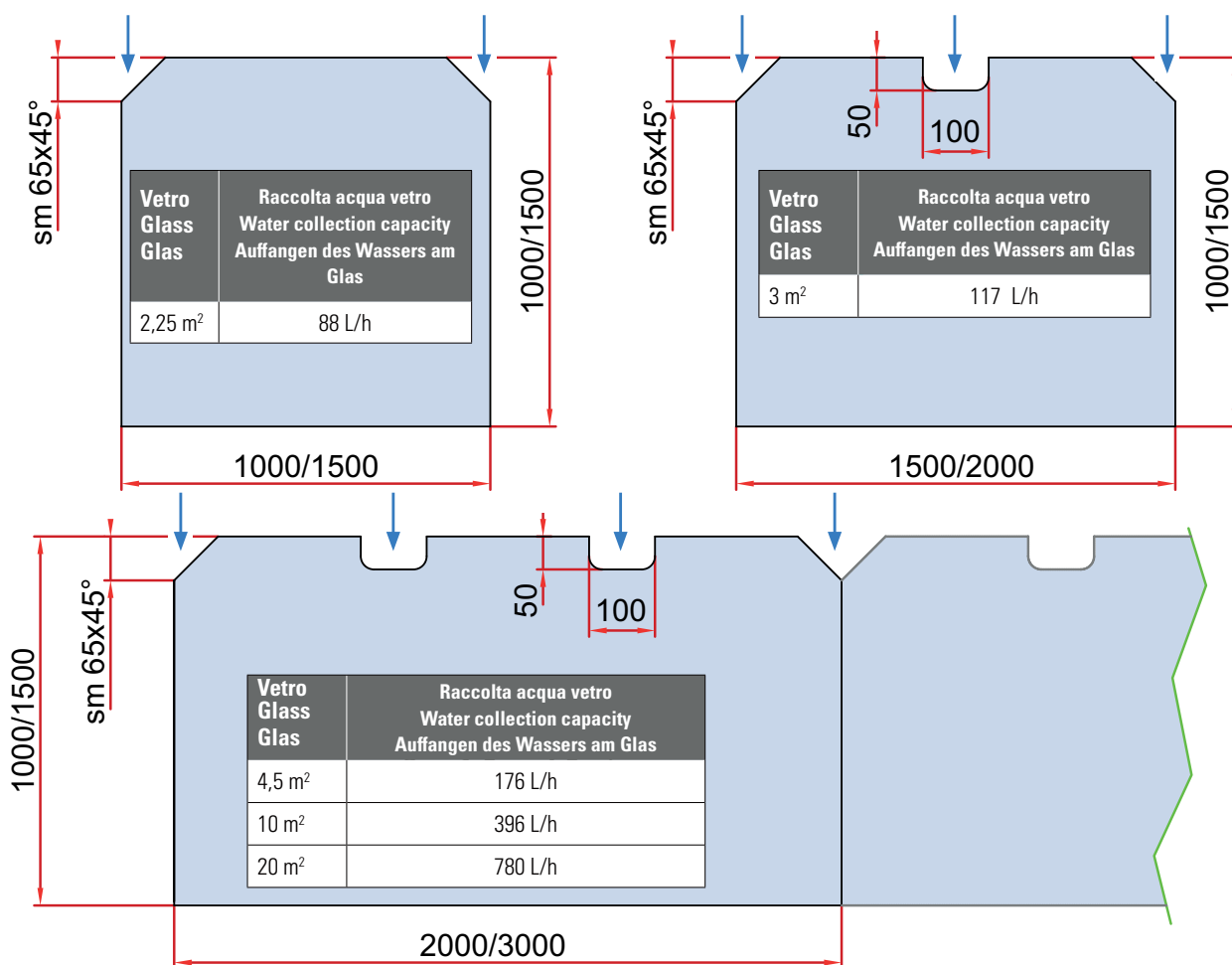
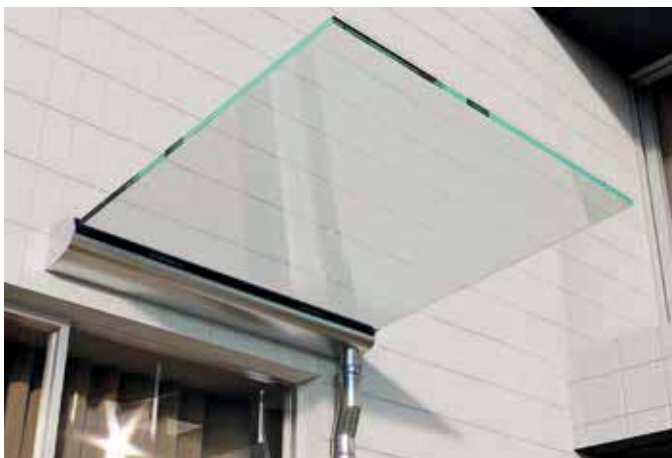

PENSILINE

CLASSIFICAZIONE DELLE PRECIPITAZIONI / RAINFALL CLASSIFICATION / EINTEILUNG DER NIEDERSCHLÄGE		
PiovigGINE / Drizzle / Nieselregen	1 mm/h	1 L/m ²
Pioggia debole / Light rain / Schwacher Regen	from 1 to 2 mm/h	from 1 to 2 L/m ²
Pioggia moderata / Steady rain / Mäßiger Regen	from 2 to 5 mm/h	from 2 to 5 L/m ²
Pioggia forte / Heavy rain / Starker Regen	from 6 to 9 mm/h	from 6 to 9 L/m ²
Rovescio / Downpour / Regenschauer	from 16 to 39 mm/h	from 16 to 39 L/m ²
Nubifragio / Storm / Wolkenbruch	40 mm/h	40 L/m ²

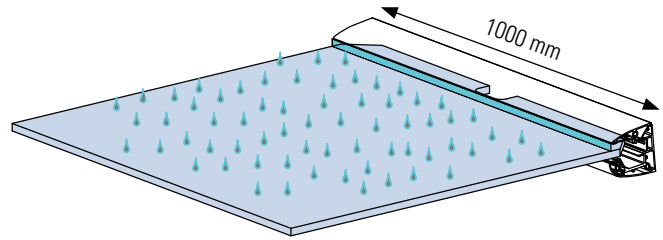

A

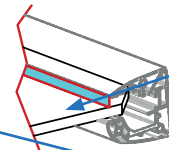
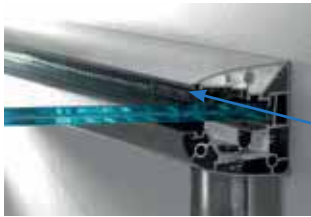

Capacità raccolta acqua L=1000 mm
Water collection capacity L=1000 mm
Auffangen des Wassers L=1000 mm
12000 mm² → 37440 L/h

B

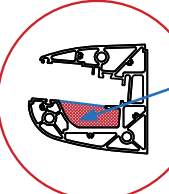

Capacità raccolta acqua con retina anti foglie
L=1000 mm
Water collection capacity with grid L=1000 mm
Auffangen des Wassers L=1000 mm
6000 mm² → 18720 L/h

C

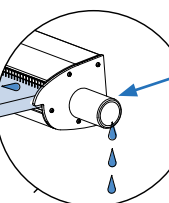
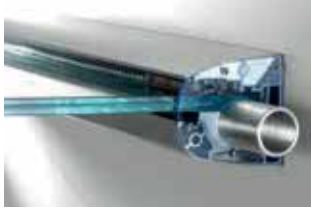

Capacità raccolta acqua:
Water collection capacity:
Auffangen des Wassers:
1320 mm² → 4104 L/h

D

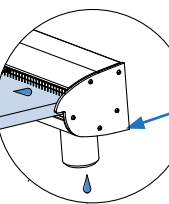

Capacità raccolta acqua:
Water collection capacity:
Auffangen des Wassers:
1260 mm² → 3924 L/h

E

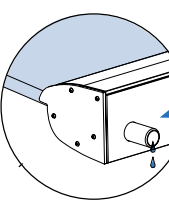

Capacità raccolta acqua:
Water collection capacity:
Auffangen des Wassers:
452 mm² → 1404 L/h

* With this solution is better to have 2 tubes

* Dati calcolati in laboratorio, secondo normativa UNI EN 12056 (coefficiente considerato di riempimento 0,33), senza presenza di detriti, foglie o altro. Per lunghi tratti verificare la fattibilità e l'esperienza.
* Data calculated in the laboratory, according to the UNI EN 12056 standard (coefficient considered with filling 0.33), without the presence of debris, leaves or other aspect. For long stretches check the feasibility and the experience.
* Daten im Labor berechnet, gemäß Norm EN 12056 (mit Füllkoeffizient 0,33), ohne Vorhandensein von Schutt, Blättern oder Sonstigem. Für lange Abschnitte sind Machbarkeit und Erfahrung zu prüfen.

KAMPIONA DRAIN

SOLUZIONE CON TIRANTE / SOLUTION WITH TENSION ROD / MÖGLICHKEIT MIT ZUGSTANGE

PER UNA MAGGIORE SPORGENZA / FOR EXTRA GLASS PROJECTION / FÜR GROßERE GLASTIEFE

